

DFC T-REX 250 PLUS INSTRUCTION MANUAL 使用說明書

RH25E04XT

ALIGN

RTF
READY TO FLY



Contents

1	INTRODUCTION 前言
1-4	SAFETY NOTES 安全注意事項
5	SAFETY CHECK BEFORE FLYING 飛行前安全檢查重要事項
6-10	PART NAMES AND OPTIONAL PART LIST 各部零件名稱與選購備品明細
11-12	SERVO INSTALLATION AND ADJUSTMENT 伺服器組裝與調整
12	ADJUSTMENTS FOR GYRO AND TAIL NEUTRAL SETTING 陀螺儀與尾翼中立點調整
13	INSTALLATION FOR ESC AND BATTERY ESC無刷調速器及電池安裝方式
13	CANOPY ASSEMBLY 機頭罩安裝
14	EQUIPMENT ILLUSTRATION 設備建議配置圖示
15	PITCH AND THROTTLE SETTING 主旋翼螺距與油門設定
16-17	TRANSMITTER USAGE AND SETTING INSTRUCTION 遙控器使用與設定說明
18-27	3GX MRS FLYBARLESS MANUAL 3GX MRS 無平衡槳系統使用說明
28	T6 RADIO CONTROL SYSTEM SETTING T6遙控器飛行設置表
29	RCC-3SX LITHIUM BATTERY BALANCE CHARGER MANUAL RCC-3SX鋰電池分壓充電器使用說明
30	POWER COLLOCATION REFERENCE 原裝動力數據參考表
30-33	ROBLENX BRUSHLESS SPEED CONTROLLER INSTRUCTION MANUAL 無刷調速器使用說明
34-35	3GX MRS FLYBARLESS PREFLIGHT CHECK 飛行前測試程序
35-38	FLIGHT ADJUSTMENT AND SETTING 飛行動作調整與設定
38-39	3GX MRS FLYBARLESS FLIGHT TEST PROCEDURE 飛行測試程序
39	TROUBLESHOOTING 飛行中狀況排除



3GX MRS
Compact
S-FHSS / DSM2 / DSMX



Thank you for buying ALIGN products. The T-REX 250 PLUS DFC is the latest technology in Rotary RC models. Please read this manual carefully before assembling and flying the new T-REX 250 PLUS DFC helicopter. We recommend that you keep this manual for future reference regarding tuning and maintenance.

承蒙閣下選用亞拓遙控世界系列產品，謹表謝意。
進入遙控世界之前必須告訴您許多相關的知識與注意事項，以確保您能夠在學習的過程中較得心應手。在開始操作之前，請務必詳閱本說明書，相信一定能夠給您帶來相當大的幫助，也請您妥善保管這本說明書，以作為日後參考。

Thank you for buying ALIGN Products. The T-REX 250 PLUS DFC Helicopter is designed as an easy to use, full featured Helicopter R/C model capable of all forms of rotary flight. Please read the manual carefully before assembling the model, and follow all precautions and recommendations located within the manual. Be sure to retain the manual for future reference, routine maintenance, and tuning. The T-REX 250 PLUS DFC is a new product developed by ALIGN. It features the best design available on the R/C helicopters market to date, providing flying stability for beginners, full aerobic capability for advanced fliers, and unsurpassed reliability for customer support.

感謝您選購亞拓產品，為了讓您容易方便的使用 T-REX 250 PLUS DFC 直昇機，請您詳細的閱讀這本說明書之後再進行組裝以及操作這台直昇機，同時您妥善的保存這本說明書，作為日後進行調整以及維修的參考。T-REX 250 PLUS DFC 是由亞拓自行研發的新產品，不論是需求飛行穩定性的初學者或是追求性能的飛行愛好者，T-REX 250 PLUS DFC 將是您最佳的選擇。

WARNING LABEL LEGEND 標誌代表涵義

 FORBIDDEN 禁止	Do not attempt under any circumstances. 在任何禁止的環境下，請勿嘗試操作。
 WARNING 警告	Mishandling due to failure to follow these instructions may result in damage or injury. 因為疏忽這些操作說明，而使用錯誤可能造成財產損失或嚴重傷害。
 CAUTION 注意	Mishandling due to failure to follow these instructions may result in danger. 因為疏忽這些操作說明，而使用錯誤可能造成危險。

IMPORTANT NOTES 重要聲明

R/C helicopters, including the T-REX 250 PLUS DFC are not toys. R/C helicopter utilize various high-tech products and technologies to provide superior performance. Improper use of this product can result in serious injury or even death. Please read this manual carefully before using and make sure to be conscious of your own personal safety and the safety of others and your environment when operating all ALIGN products. Manufacturer and seller assume no liability for the operation or the use of this product. This product is intended for use only by adults with experience flying remote control helicopters at a legal flying field. After the sale of this product we cannot maintain any control over its operation or usage.

As the user of this product, you are solely responsible for operating it in a manner that does not endanger yourself and others or result in damage to the product or the property of others.

T-REX 250 PLUS DFC 遙控直昇機並非玩具，它是結合了許多高科技產品所設計出來的休閒用品，所以商品的使用不當或不熟悉都可能造成嚴重傷害甚至死亡，使用之前請務必詳讀本說明書，勿輕忽並注意自身安全，注意，任何遙控直昇機的使用，製造商和經銷商是無法對使用者於零件使用的損耗異常或組裝不當所發生之意外負任何責任，本產品是提供給有操作過型直昇機經驗的成人或有相當技術的人員在旁指導於當地合法遙控飛行場飛行，以確保安全無虞下操作使用，產品售出後本公司將不負任何操作使用控制上的任何性能與安全責任。

作為本產品的使用者，您，是唯一對於您自己操作的環境及行為負全部的責任之人。

We recommend that you obtain the assistance of an experienced pilot before attempting to fly our products for the first time. A local expert is the best way to properly assemble, setup, and fly your model for the first time. The T-REX 250 PLUS DFC requires a certain degree of skill to operate, and is a consumer item. Any damage or dissatisfaction as a result of accidents or modifications are not covered by any warranty and cannot be returned for repair or replacement. Please contact our distributors for free technical consultation and parts at discounted rates when you experience problems during operation or maintenance. As Align Corporation Limited has no control over use, setup, final assembly, modification or misuse, no liability shall be assumed nor accepted for any resulting damage or injury. By the act of use, setup or assembly, the user accepts all resulting liability.

模型商品屬於高操作技術且為消耗性之商品，如經拆裝使用後，會造成不等情況零件損耗，任何使用情況所造成商品不良或不滿意，將無法於保證條件內更換新品或退貨，如還有使用操作維修問題，本公司會分公司或代理商將提供技術指導、特種零件供應服務。對使用者的不當使用、設定、組裝、修改、或操作不良所造成的破壞或傷害，本公司無法控制及負責。任何使用、設定、組裝、修改、或操作不良所造成的破壞、意外或傷害，使用者應承擔全部責任。

2. SAFETY NOTES 安全注意事項



- Fly only in safe areas, away from other people. Do not operate R/C aircraft within the vicinity of homes or crowds of people. R/C aircraft are prone to accidents, failures, and crashes due to a variety of reasons including, lack of maintenance, pilot error, and radio interference. Pilots are responsible for their actions and damage or injury occurring during the operation or as a result of R/C aircraft models.
- Prior to every flight, carefully check rotorhead spindle shaft screws and tail blade grip screws, linkage balls and screws, ensure they are firmly secured.
- 遙控模型飛機、直昇機屬高危險性商品，飛行時務必遠離人群，人為組裝不當或機件損壞、電子控制設備不良，以及操控上的不熟悉、都有可能導致飛行失控損傷等不可預期的意外，請飛行者務必注意飛行安全，並需了解自負疏忽所造成任何意外之責任。
- 每趟飛行前須仔細檢查，主旋翼天座轉軸螺絲、尾旋翼天座螺絲，以及機身各部位球頭、螺絲，確實上膠鎖緊才能升空飛行。

**LOCATE AN APPROPRIATE LOCATION****遠離障礙物及人群**

R/C helicopters fly at high speed, thus posing a certain degree of potential danger. Choose a legal flying field consisting of flat, smooth ground without obstacles. Do not fly near buildings, high voltage cables, or trees to ensure the safety of yourself, others and your model. For the first practice, please choose a legal flying field.
Do not fly your model in inclement weather, such as rain, wind, snow or darkness.

直升機飛行時具有一定的速度，相對的也潛在著危險性，場地的選擇也相對的重要，請遵守當地法規到合法遙控飛行場地飛行，務必選擇在空曠合法專屬飛行場地，並必須注意周圍有沒有人、高樓、建築物、高壓電線、樹木等等，避免失控的不當造成自己與他人財產的損壞。
請勿在下雨、打雷等惡劣天氣下操作，以確保本身及機體的安全。

**NOTE ON LITHIUM POLYMER BATTERIES****鋰聚電池注意事項**

Lithium Polymer batteries are significantly more volatile than alkaline or Ni-Cd/Ni-MH batteries used in RC applications. All manufacturer's instructions and warnings must be followed closely. Mishandling of Li-Po batteries can result in fire. Always follow the manufacturer's instructions when disposing of Lithium Polymer batteries.

鋰聚電池跟一般市面RC使用的鹼性電池、鎳鎘電池、鎳氫電池比較起來是相對危險的，請嚴格遵守鋰聚電池說明書之使用注意事項，不當使用鋰聚電池，可能造成火災並傷及生命財產安全，切勿大意！

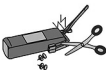
**PREVENT MOISTURE****遠離潮濕環境**

R/C models are composed of many precision electrical components. It is critical to keep the model and associated equipment away from moisture and other contaminants. The introduction or exposure to water or moisture in any form can cause the model to malfunction resulting in loss of use, or a crash. Do not operate or expose to rain or moisture.

直升機內部也是由許多精密的電子零件組成，所以必須絕對的防止潮濕或水氣，避免在浴室或雨天時使用，防止水氣滲入機身內部而導致機件及電子零件故障而引發不可預期的意外！

**PROPER OPERATION****勿不當使用本產品**

Please use the replacement of parts on the manual to ensure the safety of instructors. This product is for R/C model, so do not use for other purpose.

請勿自行改造加工，任何的升級改裝或維修，請使用亞拓產品目錄中的零件，以確保結構的安全，請確認於產品限內操作，請勿過載使用，並勿用於安全、法令外其它非法用途。

**OBTAIN THE ASSISTANCE OF AN EXPERIENCED PILOT****避免獨自操控**

Before turning on your model and transmitter, check to make sure no one else is operating on the same frequency. Frequency interference can cause your model, or other models to crash. The guidance provided by an experienced pilot will be invaluable for the assembly, tuning, trimming, and actual first flight or unforeseen danger may happen. (Recommend you to practice with computer-based flight simulator.)

至飛行前飛行前，需確認是否有相同頻率的同好正進行飛行，因為開放相同頻率的發射器將導致自己與他人立即干擾等意外危險。遙控飛機操控技巧在學溫初期有者一定的難處，要盡量避免獨自操作飛行，需有經驗的人士在旁指導，才可以操控飛行，否則將可能造成不可預期的意外發生。(動線電腦模擬器及老手指導是入門必要的選擇)

**SAFE OPERATION****安全操作**

Operate this unit within your ability. Do not fly under tired condition and improper operation may cause in danger. Never take your eyes off the model or leave it unattended while it is turned on. Immediately turn off the model and transmitter when you have landed the model.

請於自己能力內及需要一定技術範圍內操作遙控飛機，過於疲勞、精神不佳或不當操作，意外發生風險將可能提高，不可在視線範圍外進行，降落後也請馬上關閉旋翼變壓器和遙控器電源。

**ALWAYS BE AWARE OF THE ROTATING BLADES****遠離旋轉中零件**

During the operation of the helicopter, the main rotor and tail rotor will be spinning at a high rate of speed. The blades are capable of inflicting serious bodily injury and damage to the environment. Be conscious of your actions, and careful to keep your face, eyes, hands, and loose clothing away from the blades. Always fly the model a safe distance from yourself and others, as well as surrounding objects.

直昇機主旋翼與尾旋翼旋轉時會以高轉速下進行，在高轉速下的旋翼會造成自己與他人在身體上或頭項上的嚴重損傷，請勿觸摸旋轉中的主旋翼與尾旋翼，並保持安全距離以避免造成危險及損壞。

**KEEP AWAY FROM HEAT****遠離熱源**

R/C models are made of various forms of plastic. Plastic is very susceptible to damage or deformation due to extreme heat and cold climate. Make sure not to store the model near any source of heat such as an oven, or heater. It is best to store the model indoors, in a climate-controlled, room temperature environment.

遙控飛機，其旋翼多半是以PA纖維或聚乙炔、電子商品為主要材質，因此要盡量遠離熱源、日曬，以避免因高溫而變形甚至熔毀損壞的可能。



SAFETY ON THE USE OF DRY CELL BATTERIES 乾電池使用安全

The AA carbon-zinc batteries are one time use, they should not be charged for repetitive use. Please read and follow the guidelines below prior to use. The manufacturer cannot be held liable for accidents and damages as result of improper usage.

- These are one time use battery, and should not be recharged.
- Ensure proper polarity and installation method during use.
- Do not mix battery of different age or different model. Doing so may affect battery life, and even cause fire danger.
- If the product is not used for long period of time, please remove the batteries to prevent damage caused by battery leaks. Do not use batteries which exhibits symptoms of leaks.
- Please follow local law and ordinances when disposing used batteries. Do not dispose them improperly.

3號(AA)碳鋅電池，不可重複充電使用，使用前請務必詳讀並遵照下列事項，本公司將不對任何不當使用所造成的損害及意外負責。

- 碳鋅電池為一次性電池，嚴禁重複充電使用。
- 安裝使用時，請確認電池正負極位置及安裝方式。
- 嚴禁新舊或不同型號電池混用，以免影響電池使用壽命，甚至造成電池起火燃燒的危險。
- 產品長時間不使用時，請取出電池，以免造成電池電力流失或電池漏液而損壞主機。若電池已經有漏液情況，請勿再繼續使用。
- 廢棄電池，請依照該使用國家或地區的廢棄物清理法令回收，切勿任意丟棄以免污染環境。



SAFETY ON THE USE OF LITHIUM POLYMER (LIPO) BATTERIES 鋰聚電池使用安全

Lithium batteries have higher degree of risk when compared to other batteries. Please read and follow the guidelines below prior to use. The manufacturer cannot be held liable for accidents and damages as result of improper usage.

- Do not charge past 4.2v/cell; do not discharge past 3.0v/cell.
- Avoid over charging/discharging lipo batteries. Doing so may cause internal damages and affect the battery's discharge performance.
- Avoid continuous use under high temperature environment, or when battery exhibits high temperature. Doing so may shorten battery life, causing puffing of battery, or even danger of explosion.
- Discharge the batteries to 60~70% of full capacity for long term storage. Too low of voltage may result in over-discharging over time. Therefore, we recommend periodic charge of battery in long term storage, this will reduce chance of over-discharge damage.
- To avoid the danger of explosion and fire, use of third party charger to charge these batteries are prohibited.
- Avoid impact, disassembly, incorrect polarity, and burning of batteries. Avoid shorting of battery terminal by metallic objects. Avoid puncture of battery with sharp material.
- Charging error could result in battery explosion, fire, and other unexpected danger or property loss. Please always charge batteries with equipment in sight, do not leave charger unattended. Should you need to leave the charging area, please remove the battery and abort charging process.
- Should the battery exhibit excessive heat after use, do not charge immediately. Doing so may cause battery to puff, deform, explode, or even start a fire.
- Please follow local law and ordinances when disposing used batteries. Do not dispose them improperly.

鋰聚電池較其他電池有更高的危險性，使用前請務必遵照下列注意事項，本公司將不對任何不當使用所造成的損害負責。

- 充電時不得高於最大充電電壓 4.2V/cell，放電時不得低於最低放電電壓 3.0V/cell。
- 鋰聚電池要避免過充與過放的情形發生，過充或過放會對電池內部造成損傷並影響電池放電性能。
- 避免在高溫的環境或電池已經產生高溫而繼續使用，這會對電池壽命縮短，嚴重者可能會使電池膨脹甚至爆炸的危險。
- 如果長期不用時，請以 60%~70% 的充電量儲存。電量過低時，可能因自放電導致過放，因此，存放不使用的鋰聚電池時，建議定期充電，以防止自放電低於最小工作電壓而老化，避免電池充飽存放，充飽存放常會導致電池的膨脹。
- 嚴禁使用原廠以外的充電器進行充電，以免發生爆炸起火的危險。
- 嚴禁摔擊、拆解、正負極反接、焚燒電池，避免金屬品碰觸電池正負極造成短路，並請防止尖銳的物品刺穿電池，以免電池起火起火的危險。
- 電池時務必在視線範圍內進行，不可在無人看管的情形下充電，以避免因充電異常造成電池爆裂、燃燒甚至引發火災等不可預期的危險及損失。若需離開看管範圍時應將電池取出，停止對電池充電。
- 電池使用後如有發熱情況，嚴禁充電。否則會造成電池膨脹、變形、爆炸甚至起火燃燒，危害生命財產的安全。
- 廢棄電池，請依照該使用國家或地區的廢棄物清理法令回收，切勿任意丟棄以免污染環境。

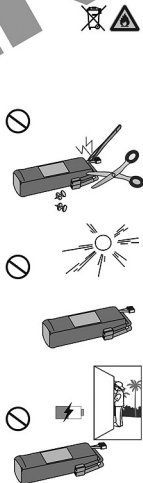

BALANCE CHARGER SAFETY PRECAUTIONS 充電器使用注意事項

FORBIDDEN 禁止

- ALIGN RCC-3SX battery charger is suitable to 2-3cell, 1000mAh and more lithium batteries. Please do not dismantle or change it for other purpose.
- If there is any unusual deformation of the surface of battery, please do not charge it anymore. If the battery becomes hot while charging, stop charging and check if the battery is broken.
- Do not let this machine drench to the rain/water or uses under the heavy moisture, in order to avoid the interior short-circuits and accidents.
- For short-circuits battery, the indicating light of the charger will be off, so please stop charging.
- Charging error could result in battery explosion, fire, and other unexpected danger or property loss. Please always charge batteries with equipment in sight, do not leave charger unattended. Should you need to leave the charging area, please remove the battery and abort charging process.
- 亞拓RCC-3SX充電器適用2-3cell、容量1000mAh以上之鋰電池。請勿自行拆卸、改裝或作為其他用途。
- 外觀已膨脹的電池不可再充電使用；損壞的電池於充電過程中會有發熱的情形，應停止對該電池進行充電。
- 勿讓本機淋到雨水或在重濕氣下使用，以免內部發生短路等不可預期的故障及意外。
- 內部短路的電池，當接上充電器時指示燈會熄滅予以警示，應停止對該電池進行充電。
- 充電時務必在視線範圍內進行，不可在無人看管的情形下充電，以避免因充電異常造成電池爆炸、燃燒甚至引發火災等不可預期的危險及損失。若需離開看管範圍時應將電池取出，停止對電池充電。

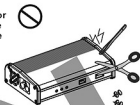

WARNING 警告

- Do not use the charger at place near heater or expose of sunshine.
- Keep the vent unimpeded.
- While using, put the charger at a stable place and avoid falling down or colliding.
- 避免靠近熱源或電器產品或在陽光直射環境下使用。
- 散熱口須保持暢通不可堵塞，以免影響散熱效果。
- 使用時請放置於平穩的場所並避免搖晃或受到外力撞擊。



CAUTION 注意

- The battery being in use may be a little hot. Please do not charge the battery right away. It might cause the battery broken, even an accident.
- Prevent liquid and anything into the device. If so, please unplug the charger and take out the battery and send it to our distributors to repair.
- Before connecting the charge to batteries, please notice the positive and negative pole of the battery. When the reverse polarity protection beeps, please take out the battery immediately. (The beeps should be stopped in 15 seconds, or the charger will be broken.)
- If there is an unusual temperature increase, swell, or other unusual occurrences, please unplug the battery and AC plug immediately.
- The electronic components of RCC-3SX can withstand a maximum input current of 0.4Amps, excess current may burned the charger and even cause a fire.
- 當電池剛使用過且表面溫度尚未冷卻時，請勿立即充電，否則將造成電池損壞，甚至引發意外。
- 不要讓異物或任何液體進入機體，如有尖利異物或任何液體進入機體時，請儘快將電源及電池拔除，並送至經銷商或本公司處理。
- 連接電池與充電器之前，請確認電池與充電器的極性是否相符，若極性錯誤將會動鳴叫警示，此時應立即將電池拔下（請即時降電壓超過15秒，以避免充電器損壞）。
- 當充電過程中發生電池溫度升高、電池膨脹或其他異常情形時，請立即拔除電池與充電器電源插頭。
- 本產品能夠承受的最大輸入電流為0.4安培，如果電流超過可能導致本產品燒毀。

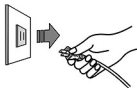

((Beep))











3. SAFETY CHECK BEFORE FLYING 飛行前安全檢查重要事項 ALIGN

CAREFULLY INSPECT BEFORE REAL FLIGHT 請嚴格執行飛行前檢查義務

- Please read the manual and ALIGN T6 RADIO CONTROL SYSTEM instruction manual before operating. Make sure you understand the basic flight knowledge and other important notes. Also always be conscious of your own personal safety with correct learning process.
- Before flight, please check if the batteries of transmitter and receiver are enough for the flight.
- Before turn on the transmitter, please check if the throttle stick is in the lowest position. IDLE switch is OFF. If they are not, the screen of the transmitter will appear warning label with warning beeps until IDLE switch is OFF and throttle stick is in the lowest position.
- When turn off the unit, please follow the power on/off procedure. Power ON- Please turn on the transmitter first, and then turn on receiver. Power OFF- Please turn off the receiver first and then turn off the transmitter. Improper procedure may cause out of control, so please to have this correct habit.
- Before operation, check every movement is smooth and directions are correct. Carefully inspect servos for interference and broken gear.
- Check for missing or loose screws and nuts. See if there is any cracked and incomplete assembly of parts. Carefully check main rotor blades and rotor holders. Broken and premature failures of parts possibly cause resulting in a dangerous situation.
- Check all ball links to avoid excess play and replace as needed. Failure to do so will result in poor flight stability.
- Check the battery and power plug are fastened. Vibration and violent flight may cause the plug loose and result out of control. When IDLE UP throttle curve function is enabled, please be careful and avoid IDLE-UP switch and caused the risk of unexpectedly speed up of the main blades.
- 在開始操作前，請務必詳閱本說明書以及ALIGN T6遙控器說明書，了解基本飛行知識與注意事項後再進行實機操作，以確保飛行安全與正確學習過程。
- 每次飛行前請確定您發射機與接收機電池的電量是在足夠飛行的狀態。
- 開機前請確認油門搖桿是否於最低點，熄火靜音開關，定速開關(IDLE)是否於關閉位置；當以上開關未於關閉位置與最低點位置，遙控器螢幕將會出現警告指示與發出警告聲音。直到開關返回關閉位置與油門搖桿放回最低點位置。
- 開機時必須遵守電源開機的程序，開機時應先開啓發射機後，再開啓接收機電源；關機時應先關閉接收機後，再關閉發射機電源。不正確的開機程序可能會造成失控的現象，影響自身與他人的安全，請養成正確的操作習慣。
- 開機請先確定選擇機器的各個動作是否順暢，及方向是否正確，並檢查伺服器的動作是否有干涉或鬆動的現象，使用故障的伺服器將導致不可預期的危險。
- 飛行前請確認沒有缺少或鬆動的螺絲與螺帽，確認沒有組裝不完整或損壞的零件，仔細檢查主變翼是否有損壞，特別是接近主旋翼夾座的部位。損壞或組裝不完整的零件不僅影響飛行，更會造成不可預期的危險。注意：對損耗、有裂損零件更新及定期保養檢查的重要性。
- 檢查所有的連接線序是否有鬆脫的現象，過鬆的連接線應先更新，否則將造成直昇機無法操控的危險。
- 確認電池及電源接頭是否固定牢靠，飛行中的震動或激烈的飛行，可能造成電源接頭鬆脫而造成失控的危險。當遙控器有設置特技飛行模式時，要小心避免不經意的切換到IDLE-UP機頭，導致主旋翼突然急劇加速變量產生的危險性。

STANDARD EQUIPMENT 標準配備

 <p>T-REX 250 PLUS DFC</p>	 <p>ALIGN T6 Transmitter ALIGN T6 遙控器</p>	
 <p>11.1V 3S 850mAh Li-Po Battery 11.1V 3S 850mAh Li-Po 電池</p>	 <p>Lithium Battery Charger 鋰電分壓充電器</p>	 <p>1.5V AA Zinc-Carbon Battery 3號碳氫電池</p>
 <p>Hook and Loop fastening tape 電池用魔术帶</p>	 <p>Hook and Loop tape 魔术沾</p>	 <p>Binding Plug 對鎖金鎖</p> <p>Plastic flat screwdriver 塑膠一字起子</p>



More parts information and specification please refer to Parts Quick Finder at ALIGN Cart.

<http://shop.align.com.tw/partfinder.php>

更多相關零件、規格，請參閱 ALIGN Cart。



WARNING
警告

Prior to every flight, carefully check rotorhead spindle shaft screws, linkage balls and screws, ensure they are firmly secured.

每趟飛行前須仔細檢查，主旋翼夾座機軸螺絲，以及機身各部位球頭、螺絲，確實上緊鎖緊才能昇空飛行。

Specifications, contents of parts and availability are subject to change. ALIGN RC is not responsible for inadvertent errors in this publications.

本說明書內的材質、規格或零件包裝之內容物僅供參考。本公司將不對此印刷物之異動負責，也無法主動通知消費者，任何更新或異動，請以亞拓網頁為主。

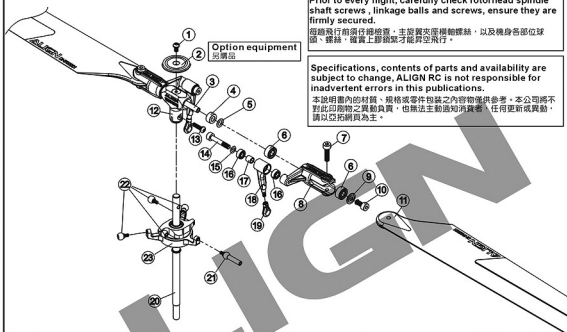

EACH LINKAGE ROD ILLUSTRATION 各連桿示意圖

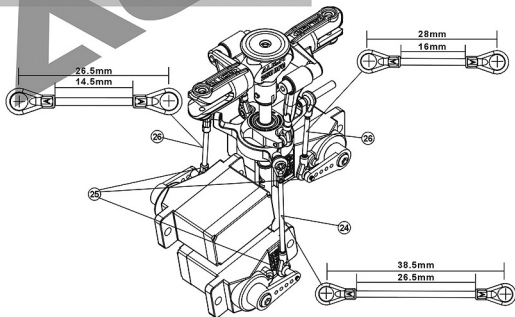

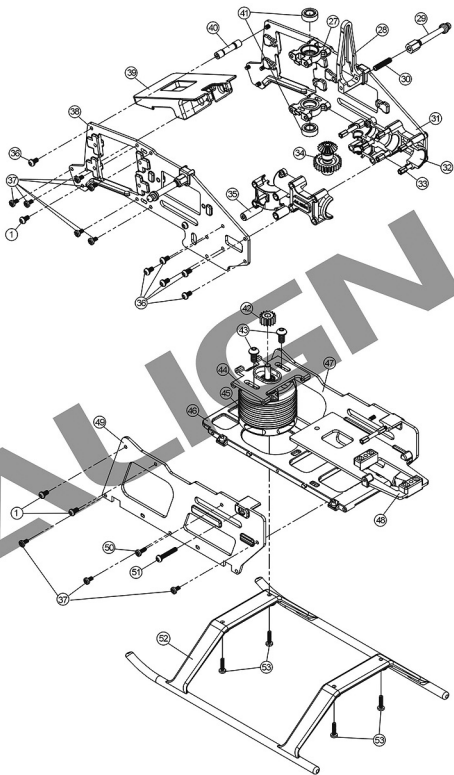

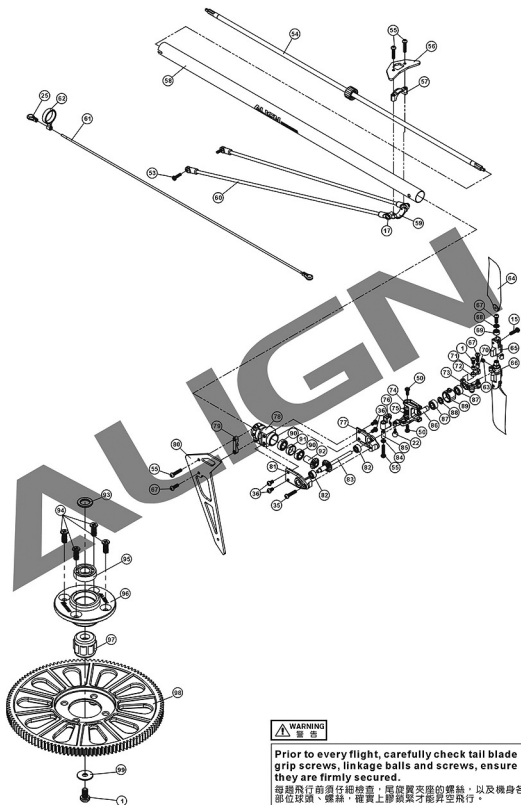

No 項次	Name 名稱	Specification 尺寸	Quantity 數量	No 項次	Name 名稱	Specification 尺寸	Quantity 數量
1	Socket button head screw 半圓頭內六角螺絲	#0-80x4mm	12	29	Canopy mounting bolt 機頭蓋固定柱	M2x23.2mm	2
2	Metal head stopper 金屬旋翼頭制動器 (Option equipment 選購品)	φ 14x3.5mm	1	30	Set screw 止動螺絲	M2x10mm	2
3	Feathering shaft 橫軸	φ 2.5x30.8mm	1	31	Carbon fiber upper frame 碳纖維上翼板(右)		1
4	Damper rubber 橫軸墊圈	φ 2.5x φ 5x2.6mm	2	32	Tail boom mount(R) 尾傳尾管固定座(右)		1
5	Spacer 橫軸墊片	φ 2.5x φ 4.5x0.2mm	2	33	Plastic hexagonal bolt 機身六角螺栓	#0-80x14mm	7
6	Bearing 軸承	φ 2.5x φ 6x2.6mm	4	34	Front drive gear assembly 尾輪傳導輪軸組	28T M0.4	1
7	Stainless steel Socket screw 不銹鋼圓頭內六角螺絲	M2x8mm	2	35	Tail boom mount(L) 尾傳尾管固定座(左)		1
8	250DFC Main Rotor Holder Set 250DFC 塑膠主旋翼夾座		2	36	Socket button head self tapping screw 半圓頭內六角自攻螺絲	#0-80x3mm	18
9	Washer 橫軸華司	φ 2x φ 5.7x0.5mm	2	37	Socket button head self tapping screw 半圓頭內六角自攻螺絲	T1.5x3mm	18
10	Socket screw 圓頭內六角螺絲	M2x5mm	2	38	Carbon fiber upper frame 碳纖維上翼板(左)		1
11	205D Carbon fiber blade 205D 碳纖維主旋翼	205mm	2	39	Battery mount 電池座		1
12	DFC Metal main rotor housing 250DFC 主旋翼固定座		1	40	Frame mounting 機身鋁固定柱	#0-80x14mm	1
13	Socket button head self tapping screw 半圓頭內六角自攻螺絲	#0-80x6mm	3	41	Bearing 軸承	φ 3.5x φ 7x2.5mm	2
14	Socket collar screw 圓頭內六角輪套螺絲	M2x12mm	2	42	Motor pinion gear 15T 馬達主齒15T	15T	1
15	Washer 華司	φ 2x φ 3.6x0.2mm	2	43	Socket button head screw 半圓頭內六角螺絲	M2.5x5mm	2
16	Bearing 軸承	φ 2x φ 4.5x2mm	4	44	Motor mount 馬達座		1
17	Main rotor griplinkage bearing sleeve 主旋翼連桿軸承套	φ 2x φ 3.2x3mm	2	45	Motor 馬達		1
18	Main rotor grip arm integrated control linkage set 主旋翼夾座連桿組		2	46	Bottom plate 底板		1
19	DFC Ball link DFC 連桿頭		2	47	Carbon fiber lower frame 碳纖維下翼板(右)		1
20	Main shaft 主軸	φ 4.5x φ 3.5x73.5mm	1	48	Gyro mount 陀螺儀座		1
21	Long linkage ball 導板長球頭	φ 3.5x13.5mm	2	49	Carbon fiber lower frame 碳纖維下翼板(左)		1
22	Linkage ball (#0-80x2mm) 球頭A (#0-80x2mm)	φ 3.5x5.3mm	7	50	Socket button head self tapping screw 半圓頭內六角自攻螺絲	T1.5x4mm	5
23	CCPM Swashplate set 十字盤組		1	51	Socket button head self tapping screw 半圓頭內六角自攻螺絲	#0-80x10mm	2
24	Linkage rod D 連桿 D	φ 1.2x32.5mm	1	52	Landing skid 腳架		2
25	Ball Linkage 連桿頭		8	53	Socket button head self tapping screw 半圓頭內六角自攻螺絲	T1.5x6mm	6
26	Linkage rod C 連桿 C	φ 1.2x21mm	2	54	Torque Tube 尾傳動轉桿	φ 2.6x252.5mm	1
27	Main shaft block 主軸固定座組		2	55	Socket button head self tapping screw 半圓頭內六角自攻螺絲	#0-80x8mm	5
28	Anti rotation bracket 金屬十字盤導板		1	56	Horizontal stabilizer 水平翼	28x13.3x1.2mm	1

No 項次	Name 名稱	Specification 尺寸	Quantity 數量	No 項次	Name 名稱	Specification 尺寸	Quantity 數量
57	Stabilizer mount(Upper) 水平固定座(上)		1	85	Metal bearing holder 尾旋翼控制臂軸套	φ1.5xφ2.5x5mm	1
58	Tail boom 尾管	φ7.9xφ8.5x241.7mm	1	86	Slide shaft 尾轉滑套		1
59	Stabilizer mount(Lower) 水平固定座(下)		1	87	Bearing 軸承	φ3xφ6x2.5mm	3
60	Tail boom brace set 尾管支撐架組	φ2x180mm	2	88	Washer 華司	φ3xφ4.8x0.6mm	1
61	Rudder control screw 尾舵控制螺桿	φ1.2x230mm	1	89	Metal Bearing mount 尾旋翼控制承套		1
62	Tail control guide 尾控制桿固定環		1	90	Bearing 軸承	φ4xφ7x2.5mm	4
63	Set screw 止鎖螺絲	M2x2mm	1	91	Tail umbrella gear 尾齒箱齒蓋		1
64	Tail blade 尾旋翼		2	92	Long umbrella gear 尾輪傳長傘齒		2
65	Metal Tail rotor holder 金屬尾旋翼夾座		2	93	Spacer 單向墊片	φ3xφ4.8x0.5mm	1
66	Tail rotor hub 尾旋翼T型座		1	94	Countersunk philips self tapping screw 圓頭十字自攻螺絲	T1.5x4mm	4
67	Socket button head self tapping screw 半圓頭內六角自攻螺絲	#0-80x5mm	5	95	Bearing 軸承	φ3xφ7x2mm	1
68	Washer 尾夾座華司	φ1.5xφ3.8x0.7mm	2	96	Main gear case 主齒中心座		1
69	Bearing 軸承	φ2xφ4.5x2mm	2	97	One-way bearing 單向軸承	φ3xφ6.5x6mm	1
70	Collar A 尾連桿頭軸套A	φ1.5xφ2.3x2.4mm	2	98	New main drive gear 新型主齒盤 120T	120T	1
71	Collar B 尾連桿頭軸套B	φ1.5xφ2.3x1.4mm	2	99	Washer 華司	φ1.5xφ5x0.3mm	1
72	Control link 新尾控制連桿頭		2				
73	T type arm 尾T型控制臂		1				
74	Metal tail pitch bellcrank 尾控制工字臂		1				
75	Bearing 軸承	φ1.5xφ4x2mm	2				
76	Metal tail pitch bellcrank mount 尾固定連接座		1				
77	Metal plate(R) 尾輪傳右側板(右)		1				
78	Torque tube drive tail unit 軸傳尾齒箱		1				
79	Vertical stabilizer mount 垂直翼固定座		1				
80	Vertical stabilizer 垂直翼		1				
81	Metal plate(L) 尾輪傳左側板(左)		1				
82	Bearing 軸承	φ2xφ5x2.5mm	4				
83	Torque Tube Rear Drive Gear Set 尾後傳動齒輪箱		1				
84	Washer 華司	φ1.5xφ3x0.5mm	1				

SERVO SETTING AND ADJUSTMENT 伺服器設定與調整

FUTABA/ALIGN T6 TRANSMITTER/SERVO FUTABA/ALIGN T6 遙控器對應伺服器關係

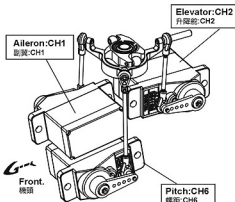

1. Servo can only be installed in this orientation when 3GX MRS is used: with head point forward, right forward is aileron (CH1), left forward is pitch (CH6), mid-rear is elevator (CH2). CH1 and CH6 cannot be interchanged, otherwise helicopter will not function correctly.
2. Swashplate type setting on the transmitter should be set to H1 traditional swashplate type. If swashplate movement is incorrect after assembly per instruction, please double check to see if 3GX MRS model setting is set to T-REX 250.

1. 使用3GX MRS 伺服器的安裝方式只有一種。當機頭朝前時，右前為副翼(CH1)，左前為彈距(CH6)，右後為升降(CH2)。CH1、CH6不可換。如果沒依照圖示連結，直昇機動作會不正確。
2. 遙控器十字檔設定，必須選擇H1傳統十字盤模式。依照圖示安裝完畢，如果十字盤動作不正確，請檢查3GX MRS機型設定是否為T-REX 250。

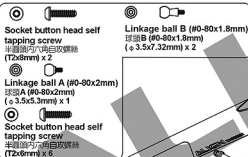

DS416M Digital Servo :

1. 1520 μ s standard band / 1520 μ s 寬頻系統
2. Stall torque/輸出扭力: 2.1kg.cm(4.8V)
2.7kg.cm(6.0V)
3. Motion speed/動作速度: 0.10sec/60° (4.8V)
0.08sec/60° (6.0V)
4. Dimension/尺寸: 22.9 x 12 x 25.8mm
5. Weight/重量: 15g

Socket button head self tapping screw
半圓頭內六角自攻螺絲
T2x6mm

Linkage ball B
球頭B
φ3.5x7.32mm

Linkage ball A
球頭A φ3.5x5.3mm

DS425M Servo
DS425M 伺服器

Socket button head self tapping screw
半圓頭內六角自攻螺絲
T2x6mm

DS425M Digital Servo:

1. 1520 μ s standard band / 1520 μ s 寬頻系統
2. Stall torque/輸出扭力: 1kg.cm(4.8V)
1.2kg.cm(6.0V)
3. Motion speed/動作速度: 0.07sec/60° (4.8V)
0.05sec/60° (6.0V)
3. Dimension/尺寸: 22.9 x 12 x 25.8mm
4. Weight/重量: 13.9g



Check if the screws are firmly tightened before flight.
飛行前再次確認螺絲是否鎖固。

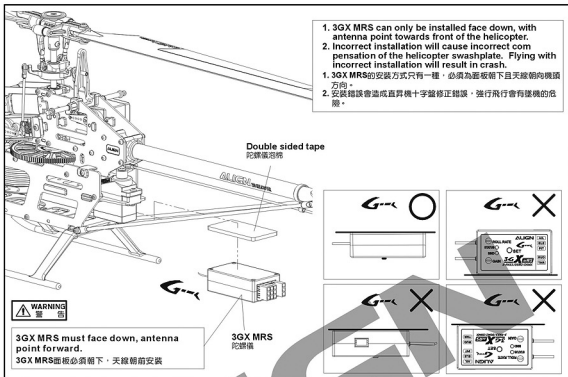

6. ADJUSTMENTS FOR GYRO AND TAIL NEUTRAL SETTING 陀螺儀與尾翼中立點設定調整

Turn off Revolution mixing (VMX) mode on the transmitter, then set the gain switch on the transmitter and the gyro to Head lock mode. The gain setting is about 45% (Futaba), and after transmitter setting, connect to the helicopter power for working on tail neutral setting.

Note: When connecting to the helicopter power, please do not touch tail rudder stick and the helicopter. Then wait for 3 seconds, make tail servo horn and tail servo at a right angle (90 degrees), tail pitch assembly must be correctly fixed about in the middle of the travel of tail rotor shaft for standard neutral setting.

發射器內陀螺儀設定請關閉被動混控模式，並將發射器上的感度開關與陀螺儀切至鎖定模式，感度設約45%左右(Futaba)，發射器設定完成後接上直昇機電源，即可進行尾中立點設定。

注意：當接上直昇機電源時請勿碰觸尾舵搖桿或直昇機機體，待3秒陀螺儀鎖定後尾尾舵桿需與尾舵桿約成90度，尾旋翼控制組須正確置於尾槳軸行程約中間位置，即為標準尾中立點設定。

TAIL NEUTRAL SETTING 尾中立點設定

After setting Head Lock mode, correct setting position of tail servo and tail pitch assembly is as photo. If the tail pitch assembly is not in the middle position, please adjust the length of rudder control rod to trim.

陀螺儀鎖定後尾伺服組與尾Pitch控制組正確擺置位置，若尾Pitch控制組未置中時請調整尾控制連桿的長度來修正。

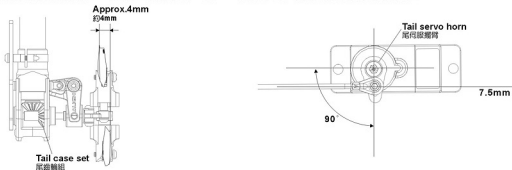

ESC INSTALLATION ESC無刷調速器安裝方式

NOTE: When installing the speed controller, please keep a distance at least 5cm from the receiver to avoid any interference.

注意：安裝ESC時請與接收器保持至少5cm以上的距離，避免干擾接收器。

ESC installation location
ESC放置位置

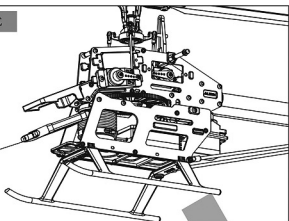
**BATTERY INSTALLATION** 電池安裝方式

Use attached Hoop and Loop Tape, tape the Hoop side (hooked) on the battery mounting plate and the Loop side (fuzzy) on the battery to fix the battery in order to prevent any slip.

以附贈的魔術沾膠帶，將公端的魔術沾(勾狀)粘貼於電池座上，母端的魔術沾(繡毛狀)粘貼於電池上，可有效固定電池避免滑動。

Hook and Loop Tape(fuzzy)
魔術沾母端
Hook and Loop Tape(hooked)
魔術沾公端

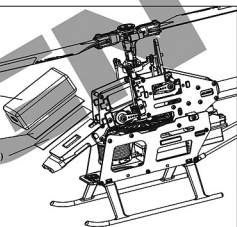
**8. CANOPY ASSEMBLY** 機頭罩安裝**ALIGN**

Canopy
機頭罩 x 1

Canopy nut
機頭罩螺絲 x 2

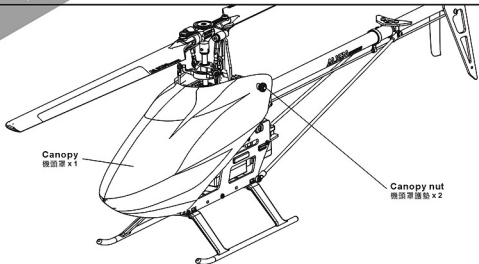

GENERAL FLIGHT 一般飛行模式



Stick position at high/Throttle 100%/Pitch+11°
搖桿高速/油門100%/Pitch+11

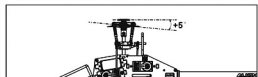

Stick position at Hovering/Throttle 70%~75%/ Pitch+5°
搖桿停滯/油門70%~75%/Pitch+5

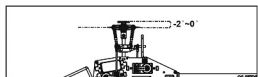

Stick position at low/Throttle 0%/Pitch-2°~0°
搖桿低速/油門0%/Pitch-2°~0°

3D FLIGHT 3D特技飛行模式



Stick position at high/Throttle 100%/Pitch+11°
搖桿高速/油門100%/Pitch+11



Stick position at middle/Throttle 85~90%/Pitch 0°
搖桿中速/油門85~90%/Pitch 0°



Stick position at low/Throttle 100%/Pitch-11°
搖桿低速/油門100%/Pitch-11°



1. Pitch range: Approx 26 (±13) degrees.
2. If the pitch is set too high, it will result in shorter flight duration and poor motor performance.
3. Setting the throttle to provide a higher speed is preferable to increasing the pitch too high.

1. 螺距(Pitch)總行程約 26° (±13°)。
2. 過大螺距設定，會導致動力與飛行時間降低。
3. 動力提升以較高轉速的設定方式，優於螺距過大的設定。

GENERAL FLIGHT
一般飛行模式

	Throttle 油門	Pitch 螺距
5	100% High speed 100% 高速	+11°
4	85%	
3	70%~75% Hovering 70%~75% 停滯	+4°~+5°
2	40%	
1	0% Low speed 0% 低速	-2°~0°

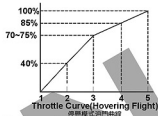

Pitch and Rotation Speed Pitch與轉速關係

TIP: It is recommended to use a lower pitch setting when using higher RPM/Head speed. This will allow for better power.

搭配要領: 如果使用較高轉速馬達動力建議搭配低 Pitch，將獲得較佳動力效能。

IDLE 1: SPORT FLIGHT

	Throttle 油門	Pitch 螺距
5	100%	+11°
4	75%	
3	70%	5°
2	75%	
1	80%	-11°

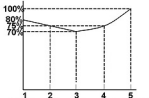

Throttle Curve (Simple Aerobatic Flight)
空中飛行模式油門曲線

IDLE 2: 3D FLIGHT

	Throttle 油門	Pitch 螺距
5	100% High 100% 高	+11°
3	85~90% Middle 85~90% 中	0°
1	100% Low 100% 低	-11°

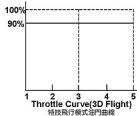

1. COMPATIBLE TRANSMITTER 通用遙控器

The 3GX MRS flybarless system in the T-REX 250 PLUS DFC RTF contains a built in S-FHSS 2.4GHz receiver, and is compatible only with similar S-FHSS transmitter. In addition, 3GX MRS also supports the use of satellite receivers, capable of binding with Spektrum DSM2/DSMX and JR DSM2 radios.

T-REX 250 PLUS DFC RTF 所搭配的3GX MRS無平衡翼系統，內建S-FHSS 2.4GHz接收模組，必須選擇一樣為S-FHSS 2.4GHz系統的遙控器才能對頻使用。另外，3GX MRS也支援衛星天線使用，可以搭配SPEKTRUM DSM2/DSMX與JR DSM2衛星天線遙控器對頻使用。



Use S-FHSS 2.4GHz transmitter
使用S-FHSS 2.4GHz系統



Using Spektrum DSM2/DSMX and JR DSM2 Radio's Satellite Receivers
使用Spektrum DSM2/DSMX、JR DSM2 衛星天線遙控器

2. SELECT H-1 SWASHPLATE TYPE 選擇H-1十字盤類型

3GX MRS supports H-1 type swashplate layout. Set the swashplate mode to H-1 in the transmitter's setting. If swashplate type is not setup properly, the control movement will not be correct, making the helicopter unflyable.

3GX MRS 支援的十字盤類型為H-1十字盤。選擇要將遙控器的十字盤選項，設定為H-1十字盤類型。如果十字盤選擇錯誤，會造成直昇機動作不正確無法飛行。



3. TRANSMITTER SETUP PARAMETERS DIAGRAM 遙控器設定表

T-REX 250 PLUS DFC RTF already has all 3GX MRS parameters configured at the factory. Just simply connect power, the helicopter will be ready to fly. The parameters in diagram below is suitable for AlignT6/Spektrum/JR transmitter, you can be adjusted to suit personal flying preference.

T-REX 250 PLUS DFC RTF出廠時已經完成3GX MRS以及T6遙控器所有設定，您只要接上電池就可以馬上享受飛行樂趣，以下也特別列出T6遙控器設定參數與SPEKTRUM/JR遙控器設定參數，您可以依照個人飛行習慣來調整遙控器參數。

ALIGN T6 AND FUTABA S-FHSS SYSTEM ALIGN T6與FUTABA S-FHSS 系統

	AIL 副翼	ELE 升降	THR 油門	RUD 尾舵	GYRO 感應	PIT 螺距
Servo Reverse 伺服器正反轉	Normal 正向	Normal 正向	Reverse 反向	Normal 正向	Normal 正向	Normal 正向
D / R 雙重比率	▲ 100 % ▼ 100 %	▲ 100 % ▼ 100 %		▲ 100 % ▼ 100 %		
EXP 動作曲線	▲ -30 % ▼ -30 %	▲ -30 % ▼ -30 %		▲ -15 % ▼ -15 %		
End Point Adjust 伺服器行程量	▲ 100 % ▼ 100 %	▲ 100 % ▼ 100 %	▲ 100 % ▼ 100 %	▲ 100 % ▼ 100 %	▲ 100 % ▼ 100 %	▲ 50 % ▼ 50 %

Swash type 十字盤類型	H-1				
Gyro gain 尾舵感應	Normal flight / 一般飛行 45 % (AVCS)			3D flight / 3D飛行 40 % (AVCS)	
Normal Throttle Curves 一般飛行油門曲線	P1	P2	P3	P4	P5
Normal Pitch Curves 一般飛行螺距曲線	0 %	42 %	65 %	78 %	100 %
IDLE-UP Throttle Curves 3D飛行油門曲線	44 %	52 %	74 %	84 %	93 %
IDLE-UP Pitch Curves 3D飛行螺距曲線	P1	P2	P3	P4	P5
	90 %	90 %	90 %	90 %	90 %
	P1	P2	P3	P4	P5
	0 %	25 %	50 %	75 %	100 %

SPEKTRUM SYSTEM SPEKTRUM 系統

	THR 油門	AIL 副翼	ELE 升降	RUD 尾舵	GYRO 感應	PIT 螺距
Servo Reverse 伺服器正反轉	Normal 正向	Reverse 反向	Reverse 反向	Reverse 反向	Normal 正向	Reverse 反向
D / R 雙重比率		▲ 100 ▼ 100	▲ 100 % ▼ 100 %	▲ 100 % ▼ 100 %		
EXP 動作曲線		▲ 30 ▼ 30	▲ 30 % ▼ 30 %	▲ 15 % ▼ 15 %		
End Point Adjust 伺服器行程量	▲ 100 % ▼ 100 %	▲ 100 % ▼ 100 %	▲ 100 % ▼ 100 %	▲ 100 % ▼ 100 %	▲ 100 % ▼ 100 %	▲ 60 % ▼ 60 %

Swash type 十字盤類型	1-Servo Normal					
Gyro gain 尾舵感應	Normal flight / 一般飛行 55 %			3D flight / 3D飛行 50 %		
Normal Throttle Curves 一般飛行油門曲線	P1	P2	P3	P4	P5	
	0 %	42 %	65 %	78 %	100 %	
Normal Pitch Curves 一般飛行螺距曲線	P1	P2	P3	P4	P5	
	44 %	52 %	74 %	84 %	93 %	
IDLE-UP Throttle Curves 3D飛行油門曲線	P1	P2	P3	P4	P5	
	90 %	90 %	90 %	90 %	90 %	
IDLE-UP Pitch Curves 3D飛行螺距曲線	P1	P2	P3	P4	P5	
	0 %	25 %	50 %	75 %	100 %	



These are the standard channel mapping when satellite receivers are used.

(1) THR (2) AIL (3) ELE (4) RUD (5) GAIN (6) PIT

使用衛星天線時，內部通道已指定為：(1) THR (2) AIL (3) ELE (4) RUD (5) GAIN (6) PIT

JR SYSTEM JR 系統

	THR 油門	AIL 副翼	ELE 升降	RUD 尾舵	GYRO 感應	PIT 螺距
Servo Reverse 伺服器正反轉	Normal 正向	Reverse 反向	Reverse 反向	Reverse 反向	Normal 正向	Reverse 反向
D / R 雙重比率		▲ 100 ▼ 100	▲ 100 % ▼ 100 %	▲ 100 % ▼ 100 %		
EXP 動作曲線		▲ 30 ▼ 30	▲ 30 % ▼ 30 %	▲ 15 % ▼ 15 %		
End Point Adjust 伺服器行程量	▲ 100 % ▼ 100 %	▲ 100 % ▼ 100 %	▲ 100 % ▼ 100 %	▲ 100 % ▼ 100 %	▲ 100 % ▼ 100 %	▲ 60 % ▼ 60 %

Swash type 十字盤類型	1-Servo Normal					
Gyro gain 尾舵感應	Normal flight / 一般飛行 75 %			3D flight / 3D飛行 70 %		
Normal Throttle Curves 一般飛行油門曲線	P1	P2	P3	P4	P5	
	0 %	42 %	65 %	78 %	100 %	
Normal Pitch Curves 一般飛行螺距曲線	P1	P2	P3	P4	P5	
	44 %	52 %	74 %	84 %	93 %	
IDLE-UP Throttle Curves 3D飛行油門曲線	P1	P2	P3	P4	P5	
	90 %	90 %	90 %	90 %	90 %	
IDLE-UP Pitch Curves 3D飛行螺距曲線	P1	P2	P3	P4	P5	
	0 %	25 %	50 %	75 %	100 %	



These are the standard channel mapping when satellite receivers are used.

(1) THR (2) AIL (3) ELE (4) RUD (5) GAIN (6) PIT

使用衛星天線時，內部通道已指定為：(1) THR (2) AIL (3) ELE (4) RUD (5) GAIN (6) PIT

FEATURES 產品特色

- 3Axis** 3-axis gyroscopic flybarless system to simulate the stability of mechanical flybar system, yet at the same time achieving agile 3D performance.
3軸陀螺儀無平衡翼系統，可模擬有平衡翼系統的穩定性，更有靈活的3D性能。
- MEMS** Utilizes MEMS gyro sensors, which feature small footprint, high reliability, and excellent stability.
採用MEMS (Micro Electro Mechanical Systems) 微機電系統技術感測器，具有體積小、可靠性高、穩定性佳的優點。
- 12bit** Sensor with 12 bit ultra high resolution, resulting in highly precise controls.
感測器12位元，超高分辨率，控制細膩精準。
- 5FHSS** Supports Futaba S-FHSS 2.4GHz transmission protocol.
支援Futaba S-FHSS 2.4GHz傳輸系統。
- +** Supports Spektrum and JR satellite receivers.
支援SPEKTRUM與JR衛星天線。
- Easy** Simplistic setup process without the need of external devices. Setup is done through 6 steps and 2 sensitivity adjustments.
設定簡單不需額外的介面，只需六個步驟、兩種敏感度調整即可完成所有設定。
- Energy** Flybarless system dramatically improves 3D power output and efficiency, resulting in reduced fuel or electricity consumption.
無平衡翼系統，可大幅降低3D大動作飛行能量消耗，提供同等機更大的動力輸出且更加節省燃油或電力。
- Stable** Highly sensitive gyroscopic sensors combined with advanced control detection routine providing higher hovering and aerobatic stability than other flybarless system.
高感度陀螺感測器及先進避障路設計，可提供比一般平衡翼系統更佳的靜態及動態穩定性。
- T-REX 250-500** Designed specifically for T-REX 250 - T-REX 450 and T-REX 500, contains optimal flight parameters, no adjustments is needed out of the box to achieve superior flight performance.
針對T-REX 250 - T-REX 450 - T-REX 500設計，內建最佳飛行參數，不需調整即有優異性能表現。
- 2.5V-8.4V** Capable to operate between 3.5V to 8.4V, compatible with high voltage servos.
適用電壓3.5V~8.4V，支援高電壓伺服器。
- ROHS** Small footprint, light weight, minimalists and reliable design.
體積小、重量輕，構造簡單可靠，提供操控者高性能的飛行樂趣。
- ROHS** RoHS certified.
符合RoHS限用規章。

3GX MRS FLYBARLESS SETUP INDICATORS 功能設定指示燈說明

FLYBARLESS SYSTEM SETUP MODE 無平衡翼系統設定模式

Flash 1 time: Aileron neutral point	閃爍頻率一次：副翼伺服器中立點設定
Flash 2 times: Elevator neutral point	閃爍頻率二次：升降伺服器中立點設定
Flash 3 times: Pitch neutral point	閃爍頻率三次：螺距伺服器中立點設定
Flash 4 times: Rudder neutral point	閃爍頻率四次：尾舵陀螺儀正反向設定
Flash 5 times: Rudder left travel limit setting	閃爍頻率五次：尾舵左舵行程設定
Flash 6 times: Rudder right travel limit setting	閃爍頻率六次：尾舵右舵行程設定

BIND LED 對頻燈號

STEADY LIT GREEN LED :Radio binding successfully	綠燈恆亮：對頻成功
FLASHING GREEN LED :Radio binding failed	綠燈閃爍：對頻失敗
STEADY LIT RED LED : No signal detected	紅燈恆亮：無發射訊號

ROLL RATE ADJUSTMENT DIAL 滾轉速率調整鈕

Roll rate dial is used to adjust the roll rate of helicopter's elevator and aileron; turning clockwise will increase roll rate, with faster elevator and aileron response; turning counter-clockwise will decrease roll rate, with slower elevator and aileron response. We recommend novice pilots to fly with lower roll rate.

滾轉速率旋鈕為調整直升機升降、副翼滾轉速率，往順時針調大滾轉速率，升降與副翼反應會變快，往逆時針調低滾轉速率，升降與副翼反應會變慢，初學入門者建議把滾轉速率調低飛行。

GAIN ADJUSTMENT DIAL 敏感度調整旋鈕

Should there be any oscillation on aileron or elevator during flight, reduce the gain by turning the dial counter-clockwise approximately 10 degrees at a time.
Should there be any drift front/rear/left/right during flight, increase the gain by turning the dial clockwise approximately 10 degrees at a time.

飛行時若機體有左右或前後抖動，表示感度偏高，請逆時針調整感度旋鈕，以每次調整約10度方式，調整至適當位置。飛行時若機體有左右或前後飄移時，表示感度偏低，請順時針調高感度旋鈕，以每次10度方式調整至適當位置。

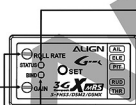

SETUP PRE-CHECK 設定前注意事項

1. During pre-flight check, please ensure 3GX MRS is securely mounted, and there are sufficient battery in the transmitter.
2. There is only one way to mount 3GX MRS on the helicopter. Do not alter the mounting direction, otherwise incorrect compensation may result in danger of crashing.
3. After 3GX MRS has bounded with transmitter, please ensure 3GX MRS power indicator is lit correctly, and that swashplate and rudder is compensating the correct direction.
4. To ensure proper initialization of 3GX MRS, please keep the helicopter stationary during power up, do not move any transmitter sticks.
5. Please ensure the swashplate setting in transmitter is set to H-1 prior to making any setting changes.
6. While setting neutral position of servos, all steps must be completed before power is turned off, otherwise servos neutral setting will fail. To ensure optimal flight performance, please ensure swashplate is level during swashplate neutral setting.
7. Adjustment of elevator and aileron roll rate must be done with the dials on 3GX MRS, do not adjust elevator and aileron travel end points on transmitter. On the other hand, rudder speed is adjusted through rudder end points.
8. To achieve optimal flight performance, pitch(CH6) and rudder (CH4) travel can be adjusted on the transmitter, but do not adjust elevator and aileron end points on transmitter.
9. Elevator and Aileron gyro gain must be adjusted through the dials on 3GX MRS NG unit. Rudder gyro gain is adjusted through transmitter's GYRO SENS function.
10. To ensure optimal signal reception, 3GX MRS antennas should be at least 1/2 inch away from conductive material, and should not be bent excessively. Try to keep the transmitter close to 3GX MRS during binding. Should it unintentionally bind to another transmitter, just perform binding process again.

1. 在每次飛行之前，請確認3GX MRS是否固定良好，並且檢查發射器電力是否足夠。
2. 3GX MRS安裝在直升機上的方式只有一種，請勿任意更改安裝方向，以免修正錯誤造成危險。
3. 發射器和3GX MRS完成對頻後，請確認3GX MRS開關燈號以及十字盤和尾舵的修正是否正確。
4. 開機時請保持直升機靜止，且不要動發射器任何搖桿，以免3GX MRS初始化錯誤。
5. 在進入所有設定之前，請確認發射器的十字盤類型須為H-1模式。
6. 在設定何種機中立點位置時，必須把全部步驟完成才可將電源關閉，否則設定值將不被記憶。設定何種空中立點位置時請將十字盤調成水平以獲得最佳飛行性能。
7. 調整升降及副翼的滾轉速率時只能用3GX MRS上的旋鈕來調整，不可利用發射器上的升降和副翼行程選項來調整。調整尾舵速率時則必須利用發射器上的尾舵行程來調整。
8. 為獲得最佳飛行性能，可以調整發射器上的螺絲(CH6)以及尾舵(CH4)的行程，但不可調整發射器上的升降和副翼行程。
9. 升降及副翼的陀螺感度必須用3GX MRS上的旋鈕調整，尾舵的陀螺感度請利用發射器的GYRO SENS選項來調整。
10. 3GX MRS的天線位置應遠離導電材料至少半英吋的距離，且不要過度彎曲，以獲得最佳的對頻信號。發射器和3GX MRS對頻時，請盡量靠近。若對到別組發射器時，重新對頻即可。

INSTALLATION 3GX MRS 接線方式



Please ensure the swashplate setting in transmitter is set to H-1 prior to making any setting changes.
請確認發射器的十字盤類型須為H-1模式。

1. Servo can only be installed in this orientation when 3GX MRS is used: with head point forward, right forward is aileron (CH1), left forward is pitch (CH6), right-rear is elevator (CH2). CH1 and CH6 cannot be interchanged, otherwise helicopter will not function correctly.
2. Swashplate type setting on the transmitter should be set to H1 traditional swashplate type.
3. If swashplate movement is incorrect after assembly per instruction, please double check to see if 3GX MRS model setting is set to T-REX 250. (See page 20)
4. To avoid damages to system, digital servos must be used for swashplate. Recommend servo specification: speed of 0.09s/60 degrees or faster; torque 2.2kg or higher.
 1. 使用3GX MRS 伺服器的安裝方式只有一種。當機頭朝前時，右前為副翼(CH1)，左前為螺絲(CH6)，右後為升降(CH2)。CH1、CH6不可換。如果沒依指示接線，直升機動作會不正確。
 2. 遙控器十字盤類型，必須選擇H1十字盤模式。
 3. 依圖式安裝完畢，如果十字盤動作不正確，請檢查3GX MRS機型設定是否為T-REX250機型檢查與設定請參閱第20頁。
 4. 十字盤必須安裝數位伺服器，否則會造成損壞。建議規格：速度0.09秒/60度以內；扭力2.2kg以上。

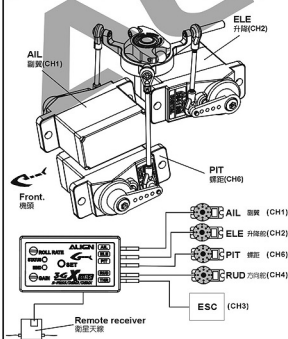

FUTABA S-FHSS SYSTEM FUTABA S-FHSS 系統

STEP1. 步驟1.

STEADY LIT GREEN LED : Radio binding successfully
 FLASHING GREEN LED : Radio binding failed
 STEADYLIT RED LED : No signal detected
 綠燈恆亮 : 對頻成功
 綠燈閃爍 : 對頻失敗
 紅燈恆亮 : 無發射訊號

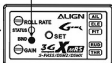

Turn on transmitter, connect 3GX MRS to power source. If signal is detected, BIND LED will flash green, otherwise it will flash red. If transmitter is turned on, but BIND is still steady red, then power cycle 3GX MRS so it will restart transmitter signal search.

打開遙控器，將3GX MRS接上電源後，若偵測到遙控器訊號，但未完成對頻BIND燈會綠燈閃爍。若已開啓發射器，但BIND燈為紅燈恆亮，請將3GX MRS重新給電源，重新尋找遙控器訊號。



If the LED status appears steady lit green, it mean the binding is successfully. Please skip Step 2.
 If the LED status appears flashing green or steady lit red, it means the binding is failed. Please proceed Step 2 for rebind.

若燈號為綠燈恆亮，代表對頻成功，不須進行步驟2重新對頻。
 若燈號為綠燈閃爍或紅燈恆亮，代表對頻失敗，則進行步驟2重新對頻。



1. Press and hold SET button
 長按SET鍵不放

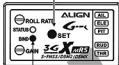

2. LED status changes from flashing red into constant green.
 燈號由紅燈閃爍轉為綠燈恆亮

STEP2. 步驟2.

Press and hold SET button, at this time BIND LED will be flashing red, hold the SET button until BIND LED shows steady green, then release SET button to complete binding.

按住SET鍵不放，此時BIND燈會紅燈閃爍，直到BIND燈顯示綠燈恆亮後，放開SET鍵即完成對頻。

USING DSM2 SATELLITE RECEIVERS 使用DSM2 衛星天線

STEP1. 步驟1.

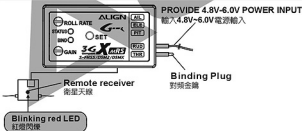

1. Plug the satellite receiver into ANT port, and the binding plug on THR channel.
2. After feeding 5-6V power through RUD or any other channels, BIND LED will turn steady red, while satellite LED flashes red.

1. 先將衛星天線接到ANT插槽，並且把對頻線接到THR通道。
 2. 由RUD或其於通道供給5-6V電源後，此將BIND燈為紅燈恆亮，衛星天線為紅燈閃爍。



Press and hold BIND button while powering up.
 按著BIND鍵開機



Remote receiver
 衛星天線

Steady red LED indicates successful binding.
 紅燈恆高表示對頻成功。

STEP2. 步驟2.

1. Press and hold the BIND button on Spektrum/JR transmitter, power on the transmitter, wait for transmitter to display iniding "Binding," then release BIND button.
2. When satellite receiver LED shows steady lit RED, remove the binding plug from THR channel.
3. When STATUS and BIND LEDs turn into steady green, this indicates binding complete and 3GX MRS initialized successfully. The system is ready for use.

1. 壓住SPEKTRUM/JR發射器的BIND按鈕後，打開發射器電源，直到發射器面板上顯示Binding字樣，在放開BIND。
 2. 等到衛星天線為紅燈恆亮後，將接到THR通道的對頻線移除。
 3. 等到STATUS和BIND燈為綠燈恆亮時，表示對頻以完成且3GX MRS開機成功，可正常執行功能。

USING DSMX SATELLITE RECEIVERS 使用DSMX 衛星天線

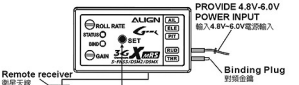

Remote receiver
衛星天線

Press and hold BIND button while powering up.
按住SET鍵不放，然後輸入電源。

Blinking red LED
紅燈閃爍

STEP 1. 步驟1.

1. Plug the satellite receiver into ANT port, and the binding plug on THR channel.
2. Press and hold the SET button on 3GX MRS, and feed 5-6V power through RUD or any other channels, BIND LED will turn steady red, while satellite LED flashes red.

1. 先將衛星天線接到ANT插槽，並且把對頻線插在THR通道。
2. 接著3GX MRS的SET鍵，再由RUD或其餘通道供給5-6V電源，此時的BIND燈為紅燈常亮，衛星天線為紅燈閃爍。

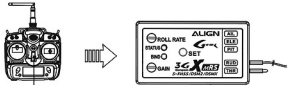

Press and hold BIND button while powering up.
按住BIND鍵不放。

Steady red LED indicates successful binding.
紅燈常亮表示對頻完成。

STEP 2. 步驟2.

1. Press and hold the BIND button on Spektrum transmitter, power on the transmitter, wait for transmitter to display "Binding", then release BIND button.
2. When satellite receiver LED shows steady lit RED, remove the binding plug from THR channel.
3. When STATUS and BIND LEDs turn into steady green, this indicates binding complete and 3GX MRS initialized successfully. The system is ready for use.

1. 壓住 SPEKTRUM/JR 發射器的 BIND 按鈕後，打開發射器電源，直到發射器屏幕上顯示 Binding 字樣，在放開 BIND。
2. 等到衛星天線為紅燈常亮後，將插在 THR 通道的對頻線移除。
3. 等到 STATUS 和 BIND 燈為綠燈常亮時，表示對頻以完成且 3GX MRS 開機成功，可正常執行功能。

CAUTION 注意

1. If both Spektrum and Futaba transmitters are powered up (both have previously bound to MRS), and a satellite receiver is connected to 3GX MRS, the 3GX MRS will select Spektrum system after power up. If no satellite receivers are connected, 3GX MRS will select Futaba system.
2. If a satellite receiver is connected to 3GX MRS, and only Futaba transmitter is powered up, 3GX MRS will select Futaba system after power up. If Spektrum transmitter is powered up afterwards, 3GX MRS will not switch over to Spektrum system.
3. On the other hand, if Spektrum transmitter is powered up and 3GX MRS has already selected Spektrum system, subsequent power up of Futaba transmitter will not cause 3GX MRS to switch over to Futaba system.

1. 如果 Spektrum 發射器和 Futaba 發射器都在開機狀態(先前都已經和 MRS 對頻)，且 3GX MRS 有接衛星天線，若此時將 3GX MRS 開機，3GX MRS 會選擇 Spektrum 系統。如果沒有接衛星天線，3GX MRS 會選擇 Futaba 系統。
2. 如果 3GX MRS 有接衛星天線，且只有 Futaba 發射器先開機，若此時將 3GX MRS 開機，3GX MRS 會選擇 Futaba 系統。即便後來再將 Spektrum 發射器開機，3GX MRS 也不會轉到 Spektrum 系統上。
3. 反之，若 Spektrum 發射器先開機，3GX MRS 選擇 Spektrum 系統後，即便再將 Futaba 發射器開機，3GX MRS 也不會轉到 Futaba 系統上。

FAILSAFE(LAST POSITION HOLD) 失控保護(保留最後指令)

When helicopter lost connectivity with your radio under this setting, all channels will hold at the last command position, except throttle channel which goes to a preset position.

1. Push throttle stick to the desired fail safe position.
2. Please refer to P.21 & P.22 binding method, and perform radio binding steps.
3. After successful binding, do not power off the 3GX MRS, unplug the binding plug and allow 3GX MRS to enter initializing process. The last position hold function will be active after the 3GX MRS initializes.
4. Test Method: Power off transmitter. The throttle channel should move to preset position, while all other channels should hold in their last position.

在此模式下，若您的直升機與遙控器失連，除油门頻道為預設位置，其餘頻道皆為最後指令位置。

1. 將油门搖桿放置於您所需要的預設安全位置
2. 依照 P.21 頁、P.22 頁的對頻方式，執行與遙控器的對頻動作。
3. 與遙控器完成對頻動作後，不要關閉 3GX MRS 電源，先將對頻線插拔，3GX MRS 會進入開機狀態，待 3GX MRS 開機完成後，即完成保留最後指令設定。
4. 測試方法：將遙控器開機，除了油门頻道為預設安全位置外，其餘頻道都為失連前的最後指令位置。

FAILSAFE(PRE-SET POSITION HOLD) 失控保護(回復預設值)

When helicopter lost connectivity with your radio under this setting, all channels will move to the pre-set position.

1. Please refer to P.21 & P.22 binding method, and power up the 3GX MRS. After the rapid flash of satellite's LEDs, Pull the binding plug off.
2. Power up radio transmitter, and perform radio binding steps. After radio is bound, LED on the satellite antennas will end the rapid flash, following by slower flash.
3. Move the transmitter sticks to the desired failsafe position while the LED is flashing in slower mode.
4. Satellite antenna's LED will lit up after 5 seconds, and 3GX MRS goes through initializing process. The failsafe position will be set after the 3GX MRS initializes.
5. Test Method: Power off transmitter, and all channels should move to the pre-set failsafe position.

在此模式下，若您的直升機與遙控器失連，所有頻道為預設安全位置。

1. 依照21頁、22頁的對頻方式，先開啟3GX MRS電源，待衛星天線上LED快速閃爍後，將對頻接頭拔除。
2. 開啟遙控器電源，執行與遙控器的對頻動作，對頻完成瞬間衛星天線上LED會由快速閃爍狀態熄滅，之後再亮起改為慢速閃爍。
3. 在慢速閃爍狀態時，將遙控器上的所有搖桿放置於您所需要的預設安全位置。
4. 5秒後衛星天線LED燈為恆亮，3GX MRS進入開機狀態，待3GX MRS開機完成後，即完成失連保護設定。
5. 測試方法：將遙控器關機，所有頻道為預設安全位置。

3GX MRS SETTINGS 3GX MRS設定



In order for the settings to stick, all 6 setting parameters for 3GX MRS must be completed followed with a press of SET button, regardless if any changes are made for each settings.

3GX MRS的六項設定，不論有無更改，皆須逐一完成，並按下SET鍵退出設定，否則3GX MRS將不會記憶設定。

3GX MRS INITIALIZATION 3GX MRS開機

Connect power, if transmitter binding is successful, BIND LED will light solid green; otherwise it will flash green. At this time, STATUS LED lights green indicates successful power up, steady green means rudder is in heading lock mode; steady red means rudder is in non-heading lock mode. Swashplate will jump up and down 3 times after power up.

接上電源，若和遙控器對頻成功後，BIND燈為綠燈恆亮，否則綠燈閃爍。此時STATUS燈亮亮起代表開機成功，綠燈恆亮，代表尾舵為鎖定，紅燈恆亮，代表尾舵為非鎖定。開機完成時，十字盤會跳三下。

Status LED steady lit
狀態燈恆亮



Binding green LED steady lit
對頻接綠燈恆亮

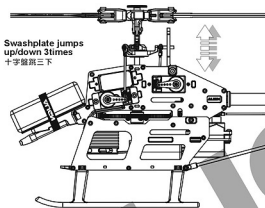

Power up transmitter, connect power to 3GX MRS. When STATUS and BIND LEDs are light steady green, SET button is used to enter setup mode.

先打開遙控器，將3GX MRS接上電源後，當STATUS和BIND燈亮為綠燈恆亮時，表示開機完成，此時按SET鍵一次即可進入設定。

ENTERING 3GX MRS SETUP 進入3GX MRS設定

After system initializes, press SET once to enter 3GX MRS setup mode. While in setup mode, STATUS LED will flash a number of times indicating the current setting selection. Press SET button to skip to next setting selection. 3GX MRS must complete all 6 setting selections before the settings are memorized.

開機完成後，按SET鍵一次就會進入3GX MRS設定。進入設定後STATUS燈會以閃爍次數代表所進入的設定選項，接續按SET鍵就會跳往下個設定選項，3GX MRS必須完成6項設定才會記憶設定內容。

Throttle stick fixed position
油門搖桿固定



- Flash 1 time: Aileron neutral point
- Flash 2 times: Elevator neutral point
- Flash 3 times: Pitch neutral point
- Flash 4 times: Rudder neutral point
- Flash 5 times: Rudder left travel limit setting
- Flash 6 times: Rudder right travel limit setting

- 閃爍頻率一次：副翼伺服器中立點設定
- 閃爍頻率二次：升降伺服器中立點設定
- 閃爍頻率三次：螺距伺服器中立點設定
- 閃爍頻率四次：尾舵左行程極限設定
- 閃爍頻率五次：尾舵右行程極限設定
- 閃爍頻率六次：尾舵右行程極限設定



Press SET button to enter Setup
按SET鍵進入設定



1. Disconnect motor to ESC to prevent accidental startup during setup.
2. The throttle stick must remain in center position during setup(or Switch HOLD), pitch curve must be at 50% position and remain fixed.

1. 設定前先拔除馬達線，避免設定中使馬達運轉造成危險。
2. 設定時油門搖桿需置於中間，螺距曲線50%輸出的位置(或切入HOLD模式)，不可再移動。

1.AILERON SERVO NEUTRAL POINT SETTING

副翼伺服器中立點設定

Momentarily press SET button first time, if STATUS LED flashes once continuously and BIND LED is off, this indicates you are in neutral setting mode of servo 1. At this time you can use RUD on transmitter to trim the neutral position of servo 1. After completing this setting it will proceed into next step.

進入3GX MRS設定的第一個設定為副翼伺服器中立點設定，STATUS燈為持續閃爍綠燈一次且BIND燈號為熄滅。此時可用遙控器尾舵桿桿微調副翼伺服器中立點位置，完成後進入下一個步驟。

Move rudder stick to adjust
撥動尾舵調整

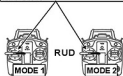

Flash green once
閃爍綠燈一次

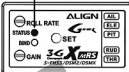

2.ELEVATOR SERVO NEUTRAL POINT SETTING

升降伺服器中立點設定

Momentarily press SET button second time, if STATUS LED flashes twice continuously and BIND LED is off, this indicates you are in neutral setting mode of servo 2. At this time you can use RUD on transmitter to trim the neutral position of servo 2. After completing this setting it will proceed into next step.

接著按SET鍵一次進入升降伺服器中立點設定，STATUS燈號為持續閃爍綠燈二次且BIND燈號為熄滅。此時可用遙控器尾舵桿桿微調升降伺服器中立點位置，設定完成後進入下一個步驟。

按著按SET鍵一次進入升降伺服器中立點設定，STATUS燈號為持續閃爍綠燈二次且BIND燈號為熄滅。此時可用遙控器尾舵桿桿微調升降伺服器中立點位置，設定完成後進入下一個步驟。

Move rudder stick to adjust
撥動尾舵調整

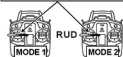

Flash green twice
閃爍綠燈二次

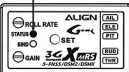

3.PITCH SERVO NEUTRAL POINT SETTING

俯仰伺服器中立點設定

Momentarily press SET button third time, if STATUS LED flashes three times continuously and BIND LED is off, this indicates you are in neutral setting mode of servo 3. At this time you can use RUD on transmitter to trim the neutral position of servo 3. After completing this setting it will proceed into next step.

接著按SET鍵一次進入俯仰伺服器中立點設定，STATUS燈號為持續閃爍綠燈三次且BIND燈號為熄滅。此時可用遙控器尾舵桿桿微調俯仰伺服器中立點位置，設定完成後進入下一個步驟。

Adjust aileron, elevator, and pitch servos' neutral point so that servo arms and washplate remain horizontal (with throttle stick at 50% position). How level your washplate is will directly affect how well the flight characteristic of 3GX MRS is.

調整副翼、升降、俯仰伺服器中立點，使伺服器擺臂與十字盤保持水平位置（此時油門桿桿須置於50%位置），十字盤的水平與與否將會直接影響3GX MRS的飛行表現與穩定性。

Move rudder stick to adjust
撥動尾舵調整



Flash green thrice
閃爍綠燈三次

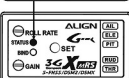

Tail moving direction 搖動尾部方向



Trim direction for
tail servo horn.
尾舵調整修正方向

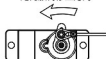

To check the head lock direction of gyro is to move the tail counter-clockwise and the tail servo horn will be trimmed counter-clockwise. If it trims in the reverse direction, please switch the gyro to "REVERSE".

尾舵陀螺儀修正方向確認：當手搖動尾部朝逆時鐘方向移動時，尾舵調整修正方向應往逆時鐘修正，修正錯誤時，換動尾舵搖桿改變尾舵陀螺儀修正方向。

4. RUDDER GYRO DIRECTION SETTING

尾舵陀螺儀修正方向設定

Momentarily press SET button fourth time, if STATUS LED flashes four times continuously and BIND LED is steady lit green, this indicates you are in rudder compensation direction setting mode. If compensation direction is correct, then skip this step. If compensation direction is reversed, use RUD on transmitter to reverse the direction, and BIND LED will change to steady lit red. After completing this setting it will proceed into next step.

接著按SET鍵一次進入尾舵陀螺儀修正方向設定，STATUS燈號為持續閃爍綠燈四次且BIND燈號為綠燈恆亮，修正方向正確，利用遙控器尾舵搖桿修正方向此時BIND燈號改變為紅燈恆亮，設定完成後進入下個步驟。

Flash green 4 times
閃爍綠燈四次



Move rudder stick to adjust
搖動尾舵調整



Green LED: normal direction
Red LED: reverse direction
250 PLUS DFC is green light
綠燈：正向 紅燈：反向
250 PLUS DFC 為綠燈

5. RUDDER LEFT TRAVEL LIMIT SETTING

尾舵左行程設定

Momentarily press SET button fifth time, if STATUS LED flashes five times continuously and BIND LED is off, this indicates you are in left rudder end point adjustment mode. At this time rudder will drift to one side. Use RUD on transmitter to set the maximum end point on left side. After completing this setting it will proceed into next step.

接著按SET鍵一次進入尾舵左行程設定，STATUS燈號為持續閃爍綠燈五次且BIND燈號為恆暗，此時尾舵會偏向單邊，利用遙控器尾舵搖桿設定尾舵向左最大的行程，設定完成後進入下個步驟。

Flash green 5 times
閃爍綠燈五次



Move rudder stick to adjust
搖動尾舵調整

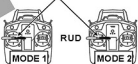

Adjust the rudder travel limit to the maximum without mechanical binding will result in better rudder gyro compensation effect.

在機構不干涉的情形下，設定較大的尾舵行程可使尾舵陀螺儀有較好的修正反應。

6. RUDDER RIGHT TRAVEL LIMIT SETTING

尾舵右行程設定

Momentarily press SET button sixth time, if STATUS LED flashes six times continuously and BIND LED is off, this indicates you are in right rudder end point adjustment mode. At this time rudder will drift to one side. Use RUD on transmitter to set the maximum end point on right side. After completing this setting it will proceed into next step.

再按SET鍵一次進入尾舵右行程設定，STATUS燈號為持續閃爍綠燈六次且BIND燈號為恆暗，此時尾舵會偏向單邊，利用遙控器尾舵搖桿設定尾舵向右最大的行程，設定完成後按SET鍵完成3GX MRS設定。

Flash green 6 times
閃爍綠燈六次

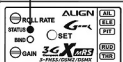

Move rudder stick to adjust
搖動尾舵調整



Adjust the rudder travel limit to the maximum without mechanical binding will result in better rudder gyro compensation effect.

在機構不干涉的情形下，設定較大的尾舵行程可使尾舵陀螺儀有較好的修正反應。



In order for the settings to stick, all 6 setting parameters for 3GX MRS must be completed followed with a press of SET button, regardless if any changes are made for each settings.

3GX MRS的六個設定，不論有無更動，皆須逐一完成，並按下SET鍵退出設定，否則3GX MRS將不會記憶設定。

MAIN ROTOR PITCH ADJUSTMENT 主旋翼螺距調整

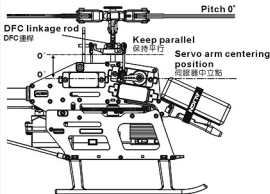

1. Press SET button to enter 3GX MRS setup mode. This setting will eliminate any washplate interaction which may affect pitch precision.
2. Move throttle stick to enter, pitch curve at 50% position. Pitch should be at 0 degrees during this setting.
3. If servo arms and washplate is already level at 0 degrees, but main rotor blades pitch is not at 0 degree, please adjust the length of DFC linkage rods to achieve 0 degrees pitch.

1. 按SET鍵進入3GX MRS設定。此時會關閉3GX MRS的陀螺儀，以避免對十字盤的修正而影響螺距的量測。
2. 將油门搖桿置中，轉距曲線90%輸出位置，請調整主旋翼螺距為0度。
3. 如果伺服臂與十字盤已經呈水平0度，但主旋翼螺距不為0度時，請調整DFC連桿長度使螺距為0度。



THRO

Disconnect motor from ESC prior to setup.

設定前，請先將馬達線拔除。

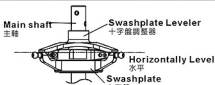

Before setting up the 3GX MRS FBL system, please use a swashplate leveler to level out the washplate to make sure the washplate is leveled to ensure 3GX MRS provides the best performance.

使用3GX MRS無平衡系統，請務必使用十字盤調整器校正十字盤，確保十字盤達到水平狀態，這樣才能確保3GX MRS飛行性能達到最佳效果。

COLLECTIVE PITCH ADJUSTMENT 集體螺距調整

The collective pitch for 3GX MRS must be adjusted in radio's EPA (End Point) function. 3GX MRS集體螺距必須從遙控器CH6 (PIT)通道的EPA (END POINT)功能中調整。

1. MAX. COLLECTIVE PITCH ANGLE 最大集體螺距角度

Push the throttle stick to the maximum, adjust maximum collective pitch value through radio's EPA function on CH6 (PIT). 將遙控器油门搖桿推至最高，使用EPA功能調整CH6 (PIT)通道的最大集體螺距角度。



Disconnect motor from ESC prior to setup. 設定前，請先將馬達線拔除。

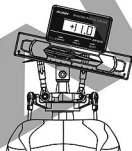



2. MIN. COLLECTIVE PITCH ANGLE 最小集體螺距角度

Push the throttle stick to the minimum, adjust minimum collective pitch value through radio's EPA function on CH6 (PIT). 將遙控器油门搖桿推至最低，使用EPA功能調整CH6 (PIT)通道的最小集體螺距角度。

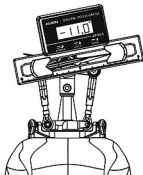

Disconnect motor from ESC prior to setup. 設定前，請先將馬達線拔除。

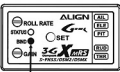
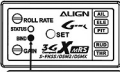
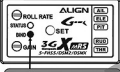

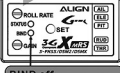
STATUS BIND	STATUS constant green STATUS 綠燈恆亮	STATUS constant red STATUS 紅燈恆亮	STATUS off STATUS 不亮
 <p>BIND constant green BIND 綠燈恆亮</p>	<p>Successful initialization and radio bounded, rudder in heading lock mode.</p> <p>完成對頻且開機成功，尾舵為鎖定狀態</p>	<p>Successful initialization and radio bounded, rudder in non-heading lock mode.</p> <p>完成對頻且開機成功，尾舵為非鎖定狀態</p>	<p>---</p>
 <p>BIND flashing green BIND 綠燈閃爍</p>	<p>Revert back to original transmitter signal that was lost during usage, rudder is in head locking mode, and detected other transition signals.</p> <p>使用過程中失去原本發射器訊號，尾舵為鎖定狀態，且偵測到其它發射器訊號</p>	<p>Revert back to original transmitter signal that was lost during usage, rudder is in non-head locking mode, and detected other transition signals.</p> <p>使用過程中失去原本發射器訊號，尾舵為非鎖定狀態，且偵測到其它發射器訊號</p>	<p>3GX MRS detects radio signal, but is not bound to the radio.</p> <p>3GX MRS 偵測到發射器訊號，但未完成對頻</p>
 <p>BIND constant red BIND 紅燈恆亮</p>	<p>Successful initialization but radio binding failed, rudder in heading lock mode.</p> <p>3GX MRS 對頻失敗，但開機成功，尾舵為鎖定</p>	<p>Successful initialization but radio binding failed, rudder in non-heading lock mode.</p> <p>3GX MRS 對頻失敗，但開機成功，尾舵為非鎖定</p>	<p>No signal detected from radio, please check if transmitter is powered on.</p> <p>3GX MRS 未偵測到發射器訊號，請確認發射器是否開啟</p>
 <p>BIND flashing red BIND 紅燈閃爍</p>	<p>---</p>	<p>---</p>	<p>Signal detected from radio, and set button was pressed for binding.</p> <p>3GX MRS 偵測到發射器訊號，且使用者正按SET鍵對頻中</p>
 <p>BIND off BIND 不亮</p>	<p>---</p>	<p>---</p>	<p>No power connecting to 3GX MRS</p> <p>3GX MRS 未連接電源</p>

SPECIFICATIONS 產品規格

1. Operating voltage range : DC 3.5V~8.4V
2. Operating current consumption : <100mA @ 4.8V
3. Rotational detection rate : $\pm 300^\circ/\text{sec}$
4. Rudder yaw detection rate : $\pm 600^\circ/\text{sec}$
5. Sensor resolution : 12bit
6. Operating temperature : $-20^\circ\text{C} \sim 65^\circ\text{C}$
7. Operating humidity : 0% ~ 95%
8. Swashplate Support : MODE H-1
9. Receiver Support : 2.4GHz S-FHSS / DSM2 / DSMX

1. 操作電壓範圍：DC 3.5 ~ 8.4V
2. 工作電流：<100mA @ 4.8V
3. 側滾及俯滾角速度範圍： $\pm 300^\circ/\text{sec}$
4. 尾舵角速度範圍： $\pm 600^\circ/\text{sec}$
5. 感測器解析度：12位元(12 BIT)
6. 操作溫度： $-20^\circ\text{C} \sim 65^\circ\text{C}$
7. 操作濕度：0% ~ 95%
8. 支援十字筒類型：H-1 模式
9. 支援發射器機類型：2.4GHz S-FHSS / DSM2 / DSMX

If you are using ALIGN T6 transmitter, please refer the following chart to setup the transmitter.
 For advanced 3D flight, please refer page 44 of ALIGN T6 RADIO CONTROL SYSTEM instruction manual.
 如果您是使用ALIGN T6遙控器，你可以參考下表來設定遙控器。要進一步進行3D飛行，可以參閱T6遙控器說明書第44頁，開啟特技飛行模式。

MENU FUNCTION 功能設置		1CH	2CH	3CH	4CH	5CH	6CH	SW
REVR	Servo Reverse 伺服器正反轉	<input type="checkbox"/> N <input type="checkbox"/> R	<input type="checkbox"/> N <input type="checkbox"/> R	<input type="checkbox"/> N <input type="checkbox"/> R	<input type="checkbox"/> N <input type="checkbox"/> R	<input type="checkbox"/> N <input type="checkbox"/> R	<input type="checkbox"/> N <input type="checkbox"/> R	
D/R	Dual Rate setting 雙速率設定	▲ 100 % ▼ 100 %	▲ 100 % ▼ 100 %		▲ 100 % ▼ 100 %			A · <input type="checkbox"/> B · I-DL
EXPO	Exponential setting 動作曲線設定	▲ -30 % ▼ 0 %	▲ -30 % ▼ 0 %		▲ 0 % ▼ 0 %			
EPA	End Point Adjust 傳感器行程量調整	▲ 100 % ▼ 100 %	▲ 100 % ▼ 100 %	▲ 100 % ▼ 100 %	▲ 100 % ▼ 100 %	▲ 100 % ▼ 100 %	▲ 50 % ▼ 50 %	
TRIM	Trims 外調	▲ 0 %	▲ 0 %	▲ 0 %	▲ 0 %			
STRM	Sub Trim 內調	▼ 0 %	▼ 0 %	▼ 0 %	▼ 0 %			
F/S	Failsafe 失控保護	<input type="checkbox"/> NOR · F/S %	<input type="checkbox"/> NOR · F/S %	<input type="checkbox"/> NOR · F/S 15 %	<input type="checkbox"/> NOR · F/S %	<input type="checkbox"/> NOR · F/S %	<input type="checkbox"/> NOR · F/S %	

MIXING SERRING 混控設定								
N-TH	Normal Throttle Curves 一般飛行模式油門曲線		P1 0 %	P2 42 %	P3 65 %	P4 78 %	P5 100 %	
N-PI	Normal Pitch Curves 一般飛行模式螺距曲線		P1 44 %	P2 52 %	P3 74 %	P4 84 %	P5 93 %	
I-TH	Idle-up Throttle Curves 特技模式油門曲線	INH · <input type="checkbox"/> ON	P1 90 %	P2 90 %	P3 90 %	P4 90 %	P5 90 %	
I-PI	Idle-up Pitch Curves 特技模式螺距曲線		P1 0 %	P2 25 %	P3 50 %	P4 75 %	P5 100 %	
HOLD	Throttle Hold 油門鎖定	INH · <input type="checkbox"/> ON	Throttle hold position				0	
H-PI	Hold Pitch Curves 油門鎖定螺距曲線		P1 0 %	P2 25 %	P3 50 %	P4 75 %	P5 100 %	
REVO	Pitch-Rudder Mixing 螺距-尾舵混控	<input type="checkbox"/> INH · <input type="checkbox"/> ON	▼ %	▲ %				
GYRO	Gyro Mixing 陀螺儀混控	INH · <input type="checkbox"/> ON	▼ 40 %	▲ 45 %	A · B ·	I-DL		
SW-T	Swash-Throttle Mixing 十字盤-油門控制	INH · <input type="checkbox"/> ON	AIL %	ELE %	RUD %			
RING	Swash Ring 十字盤環圈	INH · <input type="checkbox"/> ON	%					
SWSH	Swash Types 十字盤類型	Mode H-1	Mode HR-3 · H-3 · HE3	AIL	ELE	PIT		
DELY	Throttle Pitch Delay 油門延遲	INH · <input type="checkbox"/> ON	CH3 %	CH6 %				
HOVP	Hovering Pitch 停懸螺調	INH · <input type="checkbox"/> ON	Mode: RON · N/I					

TRAINER FUNCTION 教練模式		1CH	2CH	3CH	4CH	5CH	6CH
TRNR	Servo Reverse 伺服器正反轉	<input type="checkbox"/> INH · <input type="checkbox"/> ON	NOR · FNC OFF	NOR · FNC OFF	NOR · FNC OFF	NOR · FNC OFF	NOR · OFF NOR · OFF

ILLUSTRATION 各部名稱

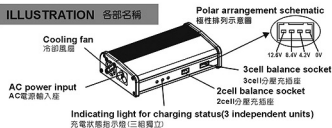

FEATURES 功能介紹

- 1.AC 100-240V exchange switch for international specification.
- 2.Apply to 3.7V/3.6V 2-3 cell Li-polymer/Li-ion batteries.
- 3.Balance charging is good to prevent the situation of over-charging or under-charging for a single cell.
- 4.Auto-detected charge status display.
(Red light: while charging/Green light: end of charging).
- 5.Cooling fan and multi-circuit protection to avoid the dangerous of charging.
- 6.The auto-detected function of low voltage for power storage.
- 7.Reverse polarity protection and short circuit protection.

INSTRUCTIONS 使用說明

1. Connect the power cord to AC power input on the main body and the power supply socket on the wall. (Apply to 100-240V alternating current)
2. Once the power is on, the three indicating lights will turn green. The waiting mode shows ready to charge.
3. Charging for DC 11.1V/10.8V 3-cell Li-ion/Li-polymer batteries:
Insert the adapters of Li-ion batteries for balance charging to 3-cell sockets in correct directions.
The 3 indicating lights will be red, showing charging status of each cell.
4. Charging for DC 7.4V 2-cell Li-polymer batteries:
Insert the adapters of Li-polymer batteries for balance charging to 2-cell sockets in correct directions.
The 2 indicating lights on the side will be red showing "on charging".
5. When the indicating lights turn green, it means charging completed. Please remove the batteries.
6. If the lights are still green when the batteries connect to the charger, it means the batteries are full of electricity. The charger will not work on the batteries.
7. Standard charging methods:
(1) Charge one set of 3-cell Li-polymer battery each time;
Fully charged battery voltage: 12.6V
(2) Charge one set of 2-cell Li-polymer battery each time;
Fully charged battery voltage: 8.4V
8. The charger has the function of supply. After the lights turn green, the charger will detect voltage of the batteries, and give a few more time of charging, until the power is full.

CHARGING COMBINATION 充電組合方式

Charging combination 每次充電組合方式	3cell balance 3cell分壓充	2cell balance 2cell分壓充	Charging time 充電所需時間
Standard mode 1 標準 mode 1	○		Battery capacity ~2000mA(Approx.) 充電時間約: 電池容量 2000mA
Standard mode 2 標準 mode 2		○	

SPECIFICATION 規格表

Model 型號	Voltage Input 輸入電壓	Voltage Output 輸出電壓	Current Output 輸出電流
RCC-3SX	AC 100-240V 50-60Hz	2cell DC 7.4V 3cell DC 11.1V	2000 mA

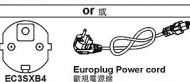

- 1.採用AC 100-240V交換式國際通用電源。輸入電壓世界各地。
- 2.適用3.7V/3.6V規格之2-3Cell Li-polymer/Li-ion充電電池。
- 3.分壓採平衡充電，有效的防止單Cell過充危險或充電不足情況。
- 4.自動偵測充電狀態燈號顯示。(充電中顯示紅燈，待充/充電完成顯示綠燈)。
- 5.內置整合式冷卻風扇及多過路保護設計，可有效避免充電危險發生。
- 6.具自動偵測電壓不足補償充電功能，有效發揮電池最大蓄電功能。
- 7.具電池極性錯誤與短路保護功能。

- 1.依所附的電源線一端連接在機體的AC電源輸入座；另一端插在牆壁的電源插座上。(適用100-200V交流電)。
- 2.當電源接入時，機體的三顆充電狀態指示燈會顯示綠色，進入待機狀態。
- 3.使用DC 11.1V/10.8V 3Cell Li-ion/Li-polymer充電：
將電池分壓充電線的接頭，依防呆缺口的方向插入標示3Cell的分壓充電座上，此時二顆只是燈顯示紅色，分別代表每cell充電的狀態。
- 4.使用DC 7.4V 2Cell Li-ion/Li-polymer充電：
將電池分壓充電線的接頭，依防呆缺口的方向插入標示2Cell的分壓充電座上二個顯示燈會顯示紅色，進入充電狀態。
- 5.當充電狀態指示燈逐一顯示為綠燈時，表示電池以充電飽，即可將電池取下。
- 6.若電池連接製充電器仍為飽電狀態，此時充電器不會對電池進行充電。
- 7.標準充電方式：
每次僅充一組3Cell的鋰電池；電池充電後的電壓為12.6V
每次僅充一組2Cell的鋰電池；電池充電後的電壓為8.4V
- 8.本充電器具充電補償功能，當充電顯示至顯示綠燈後，充電器會自動偵測電池電壓，若不足時將自動給予短時間的充電補償，使電池完全充電飽。

BATTERY 電池: ALIGN Li-Poly 11.1V 850 mAh

Motor Gear 馬達齒	Main Rotor Blade 主旋翼規格	Pitch 螺距	Current(A) approx. 電流(A)大約值	Throttle Curve 油門曲線	RPM approx. 主旋翼轉速大約值	
15T	205 Main Blades 205主旋翼	Hover 懸停	+5°	5	0/50/70/85/100%	4000
		Idle	0°	5.5	85%中	4520
			0°	6.5	100/100/100/100/100%	4950
			± 11°	11		4420
	205D Carbon Fiber Blades 205D主旋翼	Hover 懸停	+5°	4.8	0/50/70/85/100%	4100
		Idle	0°	5.3	85%中	4580
			0°	6.3	100/100/100/100/100%	5000
			± 11°	10.6		4500

NOTE: Please use a pitch gauge to adjust the pitch value. Incorrect excess pitch setting will result poor helicopter performance and reduce ESC's life and battery's life.

註: 請務必使用螺距規來量測調整螺距, 不正確的過大螺距設定不但無法發揮機器的特性, 反而會影響到無刷調速器與電池的生命。

RCM-BL250MX MOTOR RCM-BL250MX 無刷馬達

SPECIFICATION 尺寸規格

KV	KV值	3600KV(RPM/V)	Input voltage 輸入電壓	輸入電壓	2S-3S
Stator Arms 矽鋼片槽數	9		Magnet Poles 磁鐵槽數	6	
Max continuous current 最大持續電流	6A		Max instantaneous current 最大瞬間電流	24A(5sec)	
Max continuous power 最大持續功率	170W		Max instantaneous power 最大瞬間功率	250W(5sec)	
Dimension 尺寸	Shaft ϕ 2.5x25.5x29.6mm		Weight 重量	Approx. 33.5g	

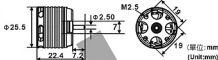

WIRING ILLUSTRATION 接線示意圖

The motor rotates in different direction with different brand ESCs. If the wrong rotating direction happens, please switch any two cables to make the motor rotates in right direction.

由於各品牌電子變速器的馬達旋轉方向不盡相同, 若發生轉向錯誤時, 請將馬達與電子變速器的接線在兩端對調即可。



16.RCE-BL15XBUSHLESS SPEED CONTROLLER INSTRUCTION MANUAL 無刷調速器使用說明

PRODUCT FEATURES 產品特色

1. 5-6V step-less adjustable BEC output allowing custom voltage setting to match servo specification.
2. BEC output utilizing switching power system, suitable for 7.4-11.1V (2S-3S) Li battery, with continuous current rating of 3A, and burst rating of 5A.
3. Three programmable throttle speed settings to support quick throttle response.
4. Include soft start and Governor Mode.
5. Small and compact PCB design for lightweight and simple installation.
6. Large heat sink for optimum thermal performance.
7. Highly compatible to work with 98% of all brushless motors currently on the market.
8. Ultra-smooth motor start designed to run with all kinds of brushless motors.
9. The power inlet utilizes a Japanese made "Low ESR" capacitor in order to provide stable power source.
10. The throttle has more than 200 step resolution that provides great throttle response and control.
1. 5-6伏特無段可調式BEC輸出, 可依伺服器規格與所需的特性自行設定電壓。
2. BEC輸入端採用交換式電源設計, 適用7.4-11.1V(2S-3S)鋰電池, 持續耐電流3A, 瞬間5A。
3. 三段可程式油門反應速度, 使動力的反應應隨隨到。
4. 具備自動及Governor Mode定速功能。
5. 體積小, 窄型設計, 安裝於機身容易。
6. 有散熱片設計, 可延長電路壽命。
7. 超相容性, 可對應市面上 98% 無刷馬達。
8. 超平滑起步設計, 無論隨選、進口、內轉、外轉無刷馬達皆起步順暢。
9. 超穩定電源採用日本製 Low ESR 低阻抗電解電容, 大降低高電壓之穩定性。
10. 油門達 200 段以上解析度, 無格數之油門感應。

SPECIFICATION 規格

Model 型號	Continuous Current 持續	Peak Current 瞬間	BEC Output BEC輸出	Dimension 尺寸	Weight 重量
RCE-BL15X	15A	20A	Output voltage: 5-6V step-less adjustment Continuous current 2A; Burst current 3A 輸出電壓: 5-6V 無段可調式 承受電流: 持續2A、瞬間3A	42x24x9.3mm	15g

1. Good temperature situation for working at the maximum current.
 2. Supporting motor types: 2~10 pole in/outrunner brushless motors.
 3. Supporting maximum RPM: 2 pole → 190,000 rpm; 6 pole → 63,000 rpm.
 4. Input voltage: 5.5V ~ 12.6V(2-3S Li-Po)
- NOTE: When setting to the Quick throttle response speed, the accelerative peak current will increase.
1. 持續最大電流需在機體散熱良好情況下。
 2. 支援馬達型式: 二極至十極之內外轉子無刷馬達。
 3. 支援最高轉速: 二極→190,000rpm; 六極→63,000rpm。
 4. 輸入電壓: 5.5V~12.6V(2-3S Li-Po)
- 注意: 設定為高油門反應速度時, 加速瞬間電流會有增大情形。

- Brake Option - 3 settings that include Brake disabled/Soft brake/Hard brake.**
- Electronic Timing Option - 3 settings that include Low timing/Mid timing/High timing.** Generally, 2 pole motors are recommended to use low timing, while 6 or more poles should use Mid timing. High timing gives more power at the expense of efficiency. Always check the current draw after changing the timing in order to prevent overloading of battery.
- Battery Protection Option- 2 settings that include Li-ion, Li-poly High/Middle cutoff voltage protection.** The default setting is high cutoff voltage protection. CPU will automatically determine cell number of input Lithium battery (2S-3S). This option will prevent over-discharge of the battery. The following reference is the guideline for setting the Battery Protection option.
 - 3-1 Li-ion/Li-poly High cutoff voltage protection-When the voltage of single cell drops to 3.2V, the first step of battery protection mode will be engaged by the ESC resulting in reduced power. The pilot should reduce the throttle and prepare landing. If the voltage of single cell drops to 3.0V, the second step of battery protection mode will be engaged resulting in power cutoff. (*Note 1) For 11.1V/3cells Lithium battery, the full charged voltage will be approximately 12.6V. According to this input voltage, CPU will determine that this is a 3cell battery.
 - First step protection: $3.2V \times 3cell = 9.6V$
 - Second step protection: $3.0V \times 3cell = 9.0V$
 - When the voltage drops to 9.6V, the power will be reduced. When the voltage drops to 9.0V, the power will be cut off.
 - 3-2 Li-ion/Li-poly Middle cutoff voltage protection- This option is same as instruction 3-1, but when the voltage of single cell drops to 3.0V, the first step of battery protection will be engaged. When the voltage of single cell drops to 2.8V, the second step of battery protection will be engaged. (*Note 1)
 - Note 1: Second step of battery protection only works when Aircraft mode is setting to the option 4-1.
 - Note 2: This option is only suitable for a fully charged battery pack in good working condition.
- Aircraft Option: 3 settings that include Normal Airplane / Helicopter 1 / Helicopter 2.** Normal Airplane Mode is used for general airplanes and gliders. When flying Helicopters, you can choose Helicopter 1 Mode, or Helicopter 2 Mode. Helicopter 1 Mode provides Soft Start feature. Helicopter 2 Mode provides Soft Start and Governor Mode.
- Throttle response speed: 3 settings that include standard/ Medium/ Quick throttle response speed.** The default setting is "quick speed". Use this option to adjust the setting according to flight character. For example, setting at Medium or Quick speed for 3D and powerful flight to make the power response more quickly, but note the accelerative peak current and power expense will increase.
- BEC output voltage setting: 5-6V step-less adjustment.**

This option allows custom voltage setting. Default setting is 5.5V; please adjust the voltage according to the specification of the servo (speed and resistance). Prior to entering the setup mode, a voltmeter needs to be connected to the power inlet of the receiver (as illustration) to monitor the selected voltage. The voltage is set by varying the throttle stick position from low (5V) to high (6V).

- 煞車設定:** 三段選擇分為無煞車 / 軟性煞車 / 急煞車
- 齒內設定:** 三段選擇分為低齒角 / 中齒角 / 高齒角
設定時機分為二種: 以六種以上無刷馬達為一類, 無刷馬達馬達一般適用低齒角, 若帶齒馬達轉速慢者, 可將齒角設定為中齒角。六種以上無刷馬達一般適用中齒角。若帶齒馬達轉速快者, 可將齒角設定為高齒角。然而齒角之調整需要注重電機之熱心, 避免過熱過載, 影響電池及馬達壽命。
- 電池保護電壓設定:** 二段選擇分為: Li-Ion / Li-Po 兩種截止電壓保護 (中截止電壓保護輸出電壓為高截止電壓保護, 此功能會自動判定所輸入連接電池的cell數 (2-3S), 並依使用者對該電池之存放保護, 避免因存放電壓過低而造成電池膨脹, 以下為設定之解說:
3-1 Li-Ion/Li-Po 高截止電壓保護: 當電壓單cell壓降達3.2V時, 電變會啟動第一階段保護, 使動力間歇性中斷, 此時使用者應將油門收小, 準備降落; 當單cell電壓持續降達3.0V時則會啟動第二階段保護, 完全強制動力輸出 (註: 僅在4-1選項, 一般飛機模式, 才會啟動第二階段保護)。例: 以一使用11.1V 3cell電池之系統而言, 1.1V單電池低於電壓約12.6V, 此輸入電壓CPU會自動判定為3cell電池。
第一階段保護: $3.2V \times 3cell = 9.6V$ 第二階段保護: $3.0V \times 3cell = 9.0V$
當電壓降至9.6V時, 動力會間歇性中斷, 當電壓降至9.0V時則完全強制動力輸出。
- 3-2 Li-Ion/Li-Po 中截止電壓保護: 自3.1V初始保護, 但單cell壓降達到3.0V時, 會啟動第一階段保護, 單cell壓降達到2.8V時啟動第二階段保護 (註1)。
註: 以上功能僅適用於Li-Ion / Li-Po 兩種截止電壓。
- 飛機模式設定:** 三段式選擇分為: 一般飛機模式 / 昇昇機模式1 / 昇昇機模式2
使用於一般飛機或滑翔機時, 請設定於一般飛機模式, 使用於昇昇機時可選擇昇昇機模式1: 具有緩啟動功能, 或昇昇機模式2: 具有緩啟動及 Governor Mode 設定功能。

- 油門反應速度設定:** 三段選擇分為標準 / 中速 / 快速
出廠設定為"快速", 油門反應速度, 此功能提供使用者依所需的飛行特性來作適當的調整, 例如 3D飛機與劇烈的 3D昇昇機飛行時可設定為中速或快速, 使動力反應更加快速、靈敏, 但請注意過高的油門反應速度時, 加速瞬間電流與耗電量皆有增大的情形。

- BEC輸出電壓設定: 5-6V step-less 調整**
本功能提供使用者自行設定 BEC 輸出電壓, 初始電壓為 5.5V, 使用者可依伺服器的規格與所需的特性 (速度與扭力) 自行更改設定, 進入此項設定前, 請先將電壓表連接到接收器的電壓端 (如圖 1), 用以監看所選擇的電壓, 設定時以油門選擇的位置來決定輸出電壓, 油門選擇最低為 5 伏特, 最高為 6 伏特, 之間的電壓值可移動油門的位置任意設定。

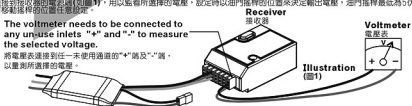

NOTE: Certain servos are designed to work with high voltage, while other servos are designed for lower voltage. To avoid damage to servos, please follow the servo's factory specification to determine the proper voltage setting.
注意: 部份伺服器不適合較高的電壓下操作, 請依原廠適用電壓規格設定, 避免造成伺服器損毀。

- Thermal Protection: When the ESC temperature reaches 80 °C for any reason, it will engage the battery protection circuit, reducing power to the ESC. We recommend mounting the ESC in a location with adequate air flow and ventilation.**
- Safe Power On Alarm: When the operator turns on the ESC, it will automatically detect the transmitter signal. The ESC will emit a continuous tone and enter normal operation mode if the throttle is set to the lowest position. If the throttle position is at full throttle, it will begin to enter Setup Mode. If the throttle is in any other position, the ESC will emit an alarm and not enter into user mode for safety precautions.**
- Aircraft Locator: If the aircraft should land or crash in an unexpected location and become lost, the pilot can enable the Aircraft Locator Option. The Aircraft Locator Option is engaged by turning off the transmitter. When the ESC does not receive a signal from the transmitter for 30 seconds, it will start to send an alarm to the motor. The sound of the alarm will aid the pilot to locate the aircraft. This option will not work with a PCM receiver that has SAVE function enabled, or with low noise resistant PPM receivers.**
- 溫度保護:** 當電變因不良之空氣對流或是過載輸出導致溫度上升達 80°C 時, 電變會啟動溫度保護, 而使動力間歇性中斷, 建議將電變裝置在機艙內空氣對流之位置, 並實際使用電流表量測輸出電流, 以達到電變之最佳效率。
- 機殼防磨損保護功能:** 當使用者關閉電變電源時, 系統會自動偵測發射機之設定, 如果發射機油門未置於最低點, 或未置於最高點準備進入設定模式, 馬達將不會轉動, 同時會有警示警響聲。
- 尋機功能:** 當飛機降落長草區無法以目視定位時, 使用者可將發射機關閉, 當電變無法接收來自接收機信號時, 電變會於 30 秒後使馬達發出警示警響, 以有定位。此功能不適用於設定了 SAVE 功能之 PCM 接收機, 或訊號抗低之 PPM 接收機。

SETUP MODE 設定模式

- Setup mode:** Make sure to connect the ESC to the throttle channel of the receiver. Please refer to the user manual of your radio system. The second step is to connect the 3 power-out signal pins to the brushless motor. Before you turn on the transmitter, please adjust the throttle stick to the maximum full throttle position. Proceed to connect the battery to the ESC. You will hear confirmation sounds as soon as you enter the SETUP MODE. Please refer the attached flow chart for details.
- Throttle stick positions in Setup mode:** Setup mode includes six settings: Brake, Electronic Timing, Battery Protection, Aircraft, Throttle Response Speed and BEC output voltage. Every setting has three options. Simply place the throttle stick in the highest, middle, and lowest positions for each setting. For example, first brake setting (Hard): move the stick to the highest position. Then timing setting (mid): move the throttle stick in the middle position.

- 進入設定模式: 將電變與接收器之油門 Channel 連接, 不同之遙控系統請參閱遙控系統之使用手冊, 馬達之三條線亦與電變連接, 將發射器之油門桿推至最高點, 使之於全油門狀態, 先開啓發射器電源, 再將電源連接到電變, 進入設定模式後, 馬達將有設定模式之提示聲音, 請參考第二頁模式化設定模式說明。
- Aircraft, Throttle Response Speed and BEC output voltage: 設定模式共有六項設定, 分別為煞車、馬達進角、電池保護、飛機模式、油門反應速度及 BEC 輸出電壓等設定, 詳細內容請參考產品功能之解說。每一項設定中各含三級設定, 各級設定以油門搖桿之上、中、下位置方式來判斷設定。例如: 煞車設定時, 油門搖桿推至最高, 則設定為急煞車, 進入第二項進角設定時, 油門搖桿推至中間, 則設定為中進角。

Mode 設定模式	Throttle position 油門搖桿	Low 低	Middle 中	High 高
Brake 煞車設定		● Brake disabled(1-1) 無煞車(1-1)	Soft brake(1-2) 軟性煞車(1-2)	Hard brake(1-3) 急煞車(1-3)
Electronic Timing 進角設定		Low-timing(2-1) 低進角(2-1)	● Mid-timing(2-2) 中進角(2-2)	High-timing(2-3) 高進角(2-3)
Battery Protection 電池保護電壓設定		● High cutoff voltage protection(3-1) 高截止電壓保護(3-1)	Middle cutoff voltage protection(3-2) 中截止電壓保護(3-2)	—
Aircraft 飛機模式設定		Normal Airplane/Glider(4-1) 一般飛機 / 滑翔機 (4-1)	● Helicopter 1 (Soft Start)(4-2) 直升機模式1(緩啟動功能) (4-2)	Helicopter 2 (Soft Start+ Governor Mode)(4-3) 直升機模式2(緩啟動+Governor Mode定速功能) (4-3)
Throttle response speed 油門反應速度設定		Standard(5-1) 標準(5-1)	Medium speed(5-2) 中速(5-2)	● Quick speed(5-3) 快速(5-3)
BEC output voltage BEC輸出電壓設定		5.0V	● 5.5V	6.0V

Note: * ● default setting
註: ● 表示出廠設定值

Chart A
表A

ESC START-UP INSTRUCTION 開機使用模式

Ensure the throttle stick is at the lowest position.

Switch on transmitter.
打開電源, 油門搖桿置於最低點, 準備進入使用操作模式



Connect battery power to ESC
雙連器接上電源, 馬達會提示

Power on sound
開機提示音

Transmitter detected sound
系統恢復OK

Current Settings Indicator Beeps
升空使用模式聲音提示

- First mode sound (Brake)
 - Second mode sound (Timing)
 - Third mode sound (Battery protection)
 - Fourth mode sound (Aircraft)
 - Fifth mode sound (Throttle response speed)
 - No sound for BEC output voltage
- 第一節模式聲音提示(煞車)
第二節模式聲音提示(進角)
第三節模式設定聲音提示(電池保護)
第四節模式聲音提示(飛機模式)
第五節模式聲音提示(油門反應速度)
BEC輸出電壓不會以聲音提示

CURRENT SETTINGS INDICATOR BEEPS EXPLANATION 開機模式設定聲音提示說明

First Beep Group Brake Status
第一節聲音 煞車設定狀態提示

- ♪ = Brake disabled
= 無煞車
- ♪♪ = Soft brake
= 軟性煞車
- ♪♪♪ = Hard brake
= 急煞車

Second Beep Group Electronic Timing
第二節聲音 進角設定狀態提示

- ♪ = Low timing (apply to 2 pole inrunner motors)
= 低進角 (適合2級內轉子馬達)
 - ♪♪ = Mid timing (apply to 6 pole in/out inner motors)
= 中進角 (適合6級內外轉子馬達)
 - ♪♪♪ = High timing (apply to high power output)
= 高進角 (適用於高功率輸出)
- High-timing/big power/power expense
高進角模式有較大功率與耗電特性

Third Beep Group
Battery Protection Cutoff
第三節聲音 電池保護設定狀態提示

- ♪ = High cutoff voltage protection
= 高截止電壓保護
- ♪♪ = Middle cutoff voltage protection
= 中截止電壓保護

Fourth Beep Group Aircraft Status
第四節聲音 飛機模式設定狀態提示

- ♪ = Normal airplane/Glider
= 一般飛機/滑翔機
- ♪♪ = Helicopter 1 (Soft start)
= 直升機模式1(緩啟動功能)
- ♪♪♪ = Helicopter 2 (Soft start + Governor Mode)
= 直升機模式2(緩啟動功能+Governor Mode定速功能)

Fifth Beep Group
Throttle Response
第五節聲音 油門反應速度設定狀態提示

- ♪ = Standard
= 標準
- ♪♪ = Medium speed
= 中速
- ♪♪♪ = Quick speed
= 快速

INSTRUCTIONS ON AIRCRAFT MODE SETTINGS 飛機模式設定使用說明

Normal Airplane/Glider Mode (Option 4-1): This option is applied to general airplanes and gliders.

Helicopter 1 Mode (Option 4-2): This option provides a soft start feature and is applied to Helicopters for Normal, Idle Up 1, or Idle Up 2 modes. Please note that the sensitivity of the gyro should be set lower when flying in Idle Up 1 or Idle Up 2 modes if tail hunting (wag) occurs due to higher rotor speed.

Helicopter 2 Mode (Option 4-3): This option supports soft start as well as Governor Mode features and is applied to Helicopters for Idle Up 1 and Idle Up 2 modes (not suitable for Normal Flight Mode). When Governor Mode is in use, the throttle should be set between 75% and 85%. Again if tail wag occurs, lower the sensitivity of the gyro to eliminate the hunting effect. The Governor Mode may not work properly in cases of insufficient rotor speed (due to improper gear ratio), poor battery discharge capability, and improper setting of gyro sensitivity and the blade pitch, etc. Please make sure all the proper adjustments have been done when using Governor Mode.

一般飛機模式(選項4-1):適用於一般飛機及滑翔機。

直升機模式1(選項4-2):具有緩啟動功能,適用於Normal、Idle1、Idle2等飛行模式,當切換至Idle1或Idle2模式,如有較高轉速造成陀螺儀有輕微的過敏現象,此時應將陀螺儀的敏感度設定分別降低。

直升機模式2(選項4-3):具有緩啟動及Governor Mode定速功能,適用於Idle1、Idle2特技飛行模式(不適合Normal飛行模式下選用),選擇定速功能時,油門應定速在75%-85%之間,如果飛行時發現有輕微的迴旋現象時,應降低陀螺儀的標度;由於轉速不足(齒比搭配不當),電池效能不佳,陀螺儀敏感度設定不當, Pitch設定錯誤,皆會導致無法發揮定速的功能,甚至產生尾部偏擺的情形,所以選擇此模式時應針對相關條件進行確認。

SETUP MODE 程式化設定模式

Minimum 4 channel radio is required 四動以上標準發射器均可執行設定

Place the throttle stick to the highest position. Switch on transmitter.

打開電源,油門搖桿置於最高點準備進入程式化功能設定模式。



1

Connect battery to ESC
變速器接上電源,馬達響音提示

Power on sound
開機確認音

Enter Setup Mode
進入設定模式



2

Throttle channel adjustment process, the highest position acknowledge sound.

油門校正程序最高點響音

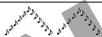

3

Place the throttle stick to the lowest sound.
Position, the lowest position acknowledge sound.

油門搖桿撥到最低點響音

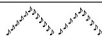

4

Use throttle stick to set preferred Brake Mode within the 5 tones.

A confirmation sound will kick in when finish.

於5音節之音響響聲時以發射器油門搖桿設定,設定連續響聲5音節後再設定,結束時將有連續響音確認。



5

Use throttle stick to set preferred Timing Mode within the 5 tones.

(Refer to Chart A) A confirmation sound will kick in when finish.

於5音節之音響響聲時以發射器油門搖桿設定,設定連續響聲5音節後再設定,結束時將有連續響音確認。



6

Use throttle stick to set preferred Battery Protection Mode within the 5 tones.

(Refer to Chart A) A confirmation sound will kick in when finish.

於5音節之音響響聲時以發射器油門搖桿設定,設定連續響聲5音節後再設定,結束時將有連續響音確認。



7

Use throttle stick to set preferred Aircraft Mode within the 5 tones.

(Refer to Chart A) A confirmation sound will kick in when finish.

於5音節之音響響聲時以發射器油門搖桿設定,設定連續響聲5音節後再設定,結束時將有連續響音確認。



8

Use throttle stick to set preferred Throttle Response Speed Mode within the 5 tones.

(Refer to Chart A) A confirmation sound will kick in when finish.

於5音節之音響響聲時以發射器油門搖桿設定,設定連續響聲5音節後再設定,結束時將有連續響音確認。



9

Use throttle stick to set preferred BEC Output Voltage Mode within 5 tones.

(Refer to Chart A) A confirmation sound will kick in when finish.

於5音節之音響響聲時以發射器油門搖桿設定,設定連續響聲5音節後再設定,輸出電壓設定,結束時將有連續響音確認。



10

STEP1 步驟1

Turn on Transmitter, and then 3GX MRS power.
先開啟遙控器電源，再開啟3GX MRS電源。

STEP2 步驟2

At this time, 3GX MRS BIND LED will lit steady green, and STATUS will be lit steady green or steady red.

此時3GX MRS BIND燈會綠燈恆亮，STATUS會綠或紅燈恆亮。

STEP3 步驟3

As shown in diagram to the left, the swashplate will twitch up and down 3 times after initialization to signal successful startup. If swashplate twitches up and down 3 times with swashplate tilted, check for correct servo installation as per instruction.

如左圖示，初始化完成後，十字盤會保持水平下小幅度跳動三次，表示完成開機程序，如十字盤為傾斜跳動三次，請檢查伺服器是否依照指示安裝。

完成開機前直昇機螺絲被固定無法動作，如果一直無法完成開機程序，請檢查開機時直昇機是否靜止或訊號線未接妥，確認後重新開機，正常開機後，STATUS亮綠燈表示尾舵為鎖定模式，亮紅燈為非鎖定模式。

Swashplate humps up/
down 3 times horizontally
十字盤水平跳動3下

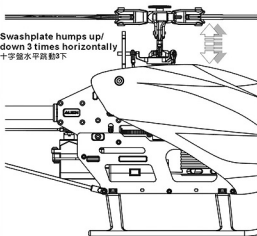

Swashplate jumps up and
down 3 times horizontally
represents successful
initialization.

十字盤水平跳動三次代表正常
開機



Swashplate jumps up and
down 3 times tilted
represents setup error.

十字盤傾斜跳動三次代表
伺服器安裝錯誤

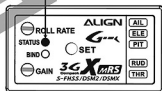

Green LED indicates rudder lock mode
Red LED indicates non-rudder lock mode
綠燈為尾舵鎖定模式
紅燈為尾舵非鎖定模式

**STEP4 步驟4**

Tilt the helicopter forward and swashplate should tilt back to compensate. If reversed, perform the flybarless initial setup again and adjust the elevator reverse setting.

將直昇機往前傾，陀螺儀應將十字盤向後修正，如果反向，請檢查3GX MRS是否依照指示安裝。

Swashplate correction
direction
十字盤修正方向

Helicopter tilting direction
機體傾斜方向

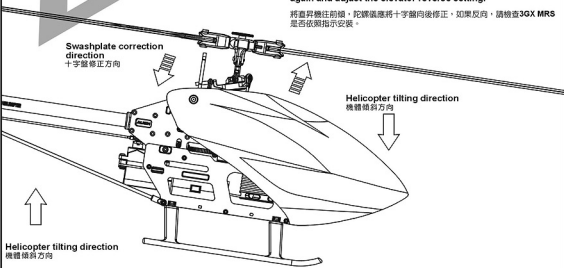

Helicopter tilting direction
機體傾斜方向

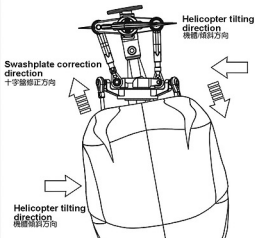
STEP5 步驟5

Tilt the helicopter right, gyro should tilt the swashplate left to compensate. If reversed, please check for the correct installation direction of 3GX MRS.

將直昇機往右傾，陀螺儀應將十字盤往左修正，如果反向，請檢查3GX MRS 是否依照指示安裝。

STEP6 步驟6

Check for proper CG location. CG needs to be at the center point below the main shaft.

檢視直昇機重心是否適當，請先調整直昇機重心位置至主軸中心線下方位置。

STEP7 步驟7

Confirm all functions are normal, power cycle the system, and begin flight test after initialization.

確定所有功能正常，重新開機，完成開機程序後進入飛行測試。

HELICOPTER CG CHECK PROCEDURE 直昇機機體重心檢視方向

After installed the battery, hold the helicopter as shown. Once the helicopter stops rotating, the helicopter's CG can be seen at where the head is pointing relative to the main shaft.

電池固定後，將直昇機如圖示舉起，待直昇機停止轉動後檢視機頭方向，正確重心應落在機身（主軸附近）位置。

Adjust the frame's CG within +/- 60 degrees from level.

以水平線上下夾角 60° 內為適當的範圍來調整機體的平衡。

**18. FLIGHT ADJUSTMENT AND SETTING 飛行動作調整與設定****ALIGN****PLEASE PRACTICE SIMULATION FLIGHT BEFORE REAL FLYING 飛行前請事先熟練模擬飛行**











A safe and effective practice method is to use the transmitter flying on the computer through simulator software sold on the market. Do a simulation flight until you familiarize your fingers with the movements of the rudders, and keep practicing until the fingers move naturally.

1. Place the helicopter in a clear open field (Make sure the power OFF) and the tail of helicopter point to yourself.
2. Practice to operate the throttle stick (as below illustration) and repeat practicing "Throttle high/low", "Aileron left/right", "Rudder left/right", and "Elevator up/down".
3. The simulation flight practice is very important, please keep practicing until the fingers move naturally when you hear operation orders being call out.

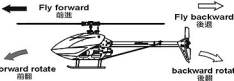
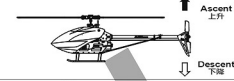

在還沒瞭解直昇機各動作的操控方式前，嚴禁實機飛行，請先進行電腦模擬飛行的練習，一種最有效、最安全的練習方式，就是透過市面販售的模擬軟體，以遙控器在電腦上模擬飛行，熟悉各種方向的操控，並不斷的重複，直到手指可熟練的控各個動作及方向。

1. 將直昇機放在空曠的地方(確認電源為關閉)，並將直昇機的機尾對準自己。
2. 練習操作遙控器的各搖桿(各動作的操作方式如下圖)，並反覆練習油门高低、副翼左右、升降舵前後及方向舵左右操作方式。
3. 模擬飛行的練習相當重要，請重複練習直到不需思索，手指能自然隨著喊出的指令移動控制。

Mode 1	Mode 2	Illustration 圖示
 <p>Aileron 副翼</p> 	 <p>Elevator 升降/前後</p> 	
 <p>Throttle 油門</p> 	 <p>Rudder 方向</p> 	  

FLIGHT ADJUSTMENT AND NOTICE FOR BEGINNERS 初學飛行調整與注意



注意

- ① Check if the screws are firmly tightened.
- ② Check if the transmitter and receivers are fully charged.
- ③ 再次確認螺絲是否鎖固?
- ④ 發射器和接收器電池是否足夠。



注意

If there are other radio control aircraft at the field, make sure to check their frequencies and tell them what frequency you are using. Frequency interference can cause your model or other models to crash and increase the risk of danger.

假使飛行場有其他遙控飛機，請確認他們的頻率，並告知他們您正在使用的頻率。相同的頻率會造成干擾導致失控和大大地增加危險。

- When arriving at the flying field.
- 當抵達飛行場



STARTING AND STOPPING THE MOTOR 啟動和停止馬達



注意

First check to make sure no one else is operating on the same frequency. Then place the throttle stick at lowest position and turn on the transmitter.

首先確認附近沒有其他相同頻率的使用，然後打開發射器將油門搖桿推到底點。

- Check the movement.
- 動作確認



ON! Step1
First turn on the transmitter.
先開發射器

- ① Are the rudders moving according to the controls?
- ② Follow the transmitter's instruction manual to do a range test.
- ③ 方向舵是否隨著控制方向移動?
- ④ 根據發射器說明書進行距離測試。



ON! Step2
Connect to the helicopter power
接上直升機電源



注意

Check if the throttle stick is set at the lowest position.
確認油門搖桿是在最低的位置。

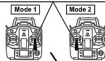

OFF! Step3
Reverse the above orders to turn off.
關閉電源時請依上述操作動作反執行。



MAIN ROTOR ADJUSTMENTS 主旋翼雙槳平衡調整



Tracking adjustment is very dangerous, so please keep away from the helicopter at a distance of at least 5m.
調整軌跡非常危險，請於距離飛機最少5公尺的距離。

1. Before adjusting, apply a red piece of tape on one blade, or paint a red stripe with a marker or paint to identify on blade.
2. Raise the throttle stick slowly and stop just before the helicopter lifts-off ground. Look at the spinning blades from the side of the helicopter.
3. Look at the path of the rotor carefully. If the two blades rotate in the same path, it does not need to adjustment. If one blade is higher or lower than the other blade, adjust the tracking immediately.

1. 調整前先在其中一支主旋翼的翼端，貼上有顏色的貼紙或畫上顏色記號，方便雙槳調整辨識。
2. 慢慢的推起油門桿得到高點並且停止，在飛機離開地面前，從飛機側邊觀察主旋翼轉動。
3. 仔細觀察雙旋翼軌跡(假如兩支旋翼移動都是相同軌跡，則不需要調整;可是如果一支旋翼較高或較低產生“雙槳”的情形時，則必須立刻調整軌跡)。

- A. When rotating, the blade with higher path means the pitch is too big. Please shorten DFC ball link for regular trim.
B. When rotating, the blade with lower path means the pitch is too small. Please lengthen DFC ball link for regular trim.

- A. 旋翼轉動時較高軌跡的主旋翼表示螺距(PITCH)過大，請調短DFC選擇修正。
B. 旋翼轉動時較低軌跡的主旋翼表示螺距(PITCH)過小，請調長DFC選擇修正。



Incorrect tracking may cause vibrations. Please repeat adjusting the tracking to make sure the rotor is correctly aligned. After tracking adjustment, please check the pitch angle is approx. $+4^{\circ}$ - 5° when hovering.

不正確的雙旋翼軌跡會導致震動，請不斷重複調整軌跡，使雙旋翼軌跡精準正確。
在調整軌跡後，確認一下Pitch角度在停懸時應為大約 $+4^{\circ}$ - 5° 。



FLIGHT ADJUSTMENT AND NOTICE FOR BEGINNERS 初學飛行調整與注意

During the operation of the helicopter, please stand approximately 10m diagonally behind the helicopter.
飛行時，請站在偏昇機後方10公尺。



- ⊙ Make sure that no one or obstructions in the vicinity.
- ⊙ You must first practice hovering for flying safety. This is a basic flight action. (Hovering means keeping the helicopter in mid air in a fixed position)
- ⊙ 確切鄰近地區沒有人和障礙物。
- ⊙ 為了飛行安全，您必須先練習停懸，這是飛行動作的基礎(停懸:直昇機滯留空中並保持固定位置)。



Beginner may install a training landing gear to avoid any crash caused by offset effect while landing.
必要時初學者可以在腳架下方安裝練習架，可避免降落時因重心偏移導致主旋翼激盪昇機墜落。



STEP 1 THROTTLE CONTROL PRACTICE 油門控制練習

When the helicopter begins to lift-off the ground, slowly reduce the throttle to bring the helicopter back down. Keep practicing this action until you control the throttle smoothly.

當直昇機開始離地時，慢慢降低油門桿飛機降下。
持續練習飛機從地面向上和斜直到你覺得油門控制很順。



STEP 2 AILERON AND ELEVATOR CONTROL PRACTICE 副翼和升降控制練習

1. Raise the throttle stick slowly.
2. Move the helicopter in any direction back, forward, left and right, slowly move the aileron and elevator sticks in the opposite direction to fly back to its original position.

1. 慢慢升起油門桿。
2. 使直昇機按指示:移動向後/向前/向左/向右，慢慢的反向移動副翼和升降桿並將直昇機回到原來位置。



- ⊙ If the nose of the helicopter moves, please lower the throttle stick and land the helicopter. Then move your position diagonally behind the helicopter 5m and continue practicing.
- ⊙ If the helicopter flies too far away from you, please land the helicopter and move your position behind 5m and continue practicing.
- ⊙ 當直昇機機頭偏移時，請降低油門並且降落，然後移動自己的位置到直昇機的正後方5公尺再繼續練習。
- ⊙ 假如直昇機飛離你太遠，請先降落直昇機，並到直昇機後5公尺再繼續練習。

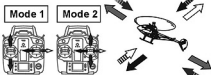

STEP 3 RUDDER CONTROL PRACTICING 方向舵操作練習

1. Slowly raise the throttle stick.
2. Move the nose of the helicopter to right or left, and then slowly move the rudder stick in the opposite direction to fly back to its original position.

1. 慢慢升起油門桿。
2. 將直昇機機頭移動左或右，然後慢慢反向移動方向舵桿並將直昇機飛回原本位置。

STEP 4

After you are familiar with all actions from Step1 to 3, draw a circle on the ground and practice within the circle to increase your accuracy.

◎ You can draw a smaller circle when you get more familiar with the actions.

當您覺得 Step1-3 動作熟悉了，在地上畫個圈並在這個圈內的範圍內練習飛行，以增加您操控的準確度。

◎ 當您更加習慣操作動作，您可以畫更小的圈。



STEP 5 DIRECTION CHANGE AND HOVERING PRACTICE 改變直昇機方向和練習停懸

After you are familiar with Step1 to 4, stand at side of the helicopter and continue practicing Step1 to 4. Then repeat the Step1 to 4 by standing in front of the helicopter.

當您覺得Step1-4動作熟悉了，站在對直昇機側面並繼續練習Step1-4。之後，站在直昇機機頭前方重複步驟練習。

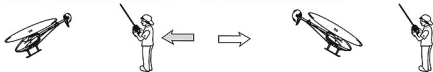

19. 3GX MRS FLYBARLESS FLIGHT TEST PROCEDURE 飛行測試程序 ALIGN

ELEVATOR AND AILERON GAIN ADJUSTMENT 升降及副翼陀螺儀感度調整

Hover the helicopter and observe if there are any left / right or forward / backward fast oscillation. If oscillation exists, turn the gain dial counter-clockwise to reduce the gyro gain.

先將直昇機以停懸飛行，觀察直昇機左右及前後是否有不正常快速抖動現象，如果前後或左右有抖動，請將感度旋鈕逆時鐘調低，以減少陀螺儀修正感度。

SET THE DIAL TO 12 O'CLOCK POSITION AS STARTING POINT 建議初次飛行設於12點鐘方向

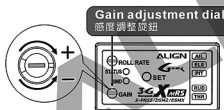

Decrease lock gain sensitivity
調降鎖定感度

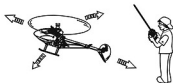

Forward/back oscillation · Left/right oscillation
前後晃動 / 左右晃動

FORWARD STRAIGHT LINE FLIGHT 前進直線航道飛行

After hovering, proceed to fast forward flight. Should there be similar oscillation, please reduce gain. Should the helicopter pitch up or experience slow response during flight, increase gain. Repeat this process until ideal gain value is achieved. Pilot can also adjust the cyclic EXP setting for the preferred stability. After all adjustments are completed, the pilot can enjoy the stability of slow flight and the fast agility from flybarless system.

停懸完後可快速前進飛行，同樣的如果有不正常抖動時，請將感度調小，飛行時如果有機頭向上仰起或反應緩慢現象時，請將感度調大，重複測試將感度調整至最理想值，使用者也可依據個人經驗調整舵面EXP以增添停旋穩定性，完成所有調整後，就可享受3GX MRS所提供低速飛行的穩定性及高速時的靈活度。



ROLL RATE ADJUSTMENT 滾轉速率調整

Roll rate dial is used to adjust the roll rate of helicopter's elevator and aileron; turning clockwise will increase roll rate, with faster elevator and aileron response; turning counter-clockwise will decrease roll rate, with slower elevator and aileron response. We recommend novice pilots to fly with lower roll rate.

滾轉速率旋鈕調整升降、副翼滾轉速率，往順時針調大滾轉速率，升降與副翼動作反應會變快，在逆時針調低滾轉速率，升降與副翼動作反應會變慢，初接入手建議把滾轉速率調低飛行。

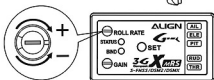

Adjust Counter-clockwise for less sensitive response
逆時針調整，直昇機反應較緩和

RUDDER SENSITIVITY ADJUSTMENT 尾舵敏感度調整

Actual gain value differs amongst servos and helicopters. The goal is to find the maximum gain without tail hunting. This can only be done through actual flight tests.

The recommended starting point for transmitter's gyro gain setting should be 45-50% for hovering, 40-45% (Futaba) for IDLE-UP. Value should be tuned under actual flight conditions by increasing to the maximum gain without tail hunting.

感度值的大小會隨著伺服器與直昇機的不同而有所差異，一般而言，在不產生追蹤現象（直昇機尾部出現左右搖擺的情況）的前提下感度值愈高愈好，所以只能透過實際飛行的狀況來進行調整。

進入遙控器感度設定的選項，剛開始停懸時建議先設定在45-50% (Futaba)左右，IDLE UP飛行時設定在40-45%左右，之後再依實際飛行的狀態再行修正，如果沒有追蹤現象發生時可再調整高感度，若發生追蹤現象時，則調低感度。

20. TROUBLESHOOTING 飛行中狀況排除

	Problem 狀況	Cause 原因	Solution 對策
Blade Tracking 雙槳平衡	Tracking is Off 雙槳	DFC linkage rods are not even length DFC連桿長度調整不平均	Adjust length of pitch linkage rods (A) 調整DFC連桿槓長度
Hover 停懸	Headspeed too low 主旋翼轉速偏低	Excessive pitch 主旋翼的PITCH偏高	Adjust pitch linkage rods (A) to reduce pitch by 4 to 5 degrees. Hovering headspeed should be around 4000RPM. 調整連桿槓調高Pitch約+4-5度 (停懸時主旋翼轉速約4000RPM)
		Hovering throttle curve is too low 停懸點油門曲線過低	Increase throttle curve at hovering point on transmitter (around 65%) 調高停懸點油門曲線約(65%)
	Headspeed too high 主旋翼轉速偏高	Not enough pitch 主旋翼的PITCH偏低	Adjust pitch linkage rods (A) to increase pitch by 4 to 5 degrees. 調整連桿槓調高Pitch約+4-5度
		Hovering throttle curve is too high 停懸點油門曲線過高	Decrease throttle curve at hovering point on transmitter (around 65%) 調低停懸點油門曲線約(65%)
Rudder Response 尾舵反應	Drifting of tail occurs during hovering, or delay of rudder response when centering rudder stick. 停懸時尾舵向某一邊偏移，或操舵方向舵並回彈到中立點時，尾翼產生延遲，無法停懸在所控制位置上。	Rudder neutral point improperly set 尾舵中立點設定不準 Rudder gyro gain too low 尾舵陀螺儀感度偏低	Reset rudder neutral point 重設尾舵中立點 Increase rudder gyro gain 增加尾舵陀螺儀感度
	Tail oscillates (hunting, or wags) at hover or full throttle 停懸或全油門時尾翼左右來回搖擺。	Rudder gyro gain too high 尾舵陀螺儀感度偏高	Reduce rudder gyro gain 降低尾舵陀螺儀感度
Oscillation during flight 飛行抖動	Helicopter oscillates forward/backward/left/right while performing cyclic maneuvers. 升降舵或副翼打舵動作時，機體前後左右抖動	Swashplate gyro gain is slightly too high. 十字盤陀螺儀感度偏高，產生追蹤現象	Turn the gain dial on 3GX MRS counter-clockwise, 10 degrees at a time until oscillation is eliminated. 逆時針調整3GX MRS上的感度調整旋鈕，以每次調整約10度的方式，調整至適當位置
	Helicopter front bobbles (nods) during forward flight. 直線飛行時，機頭點頭	Worn servo, or slack in control links 伺服器老化，控制結構有虛位	Replace servo, ball link, or linkage balls. 更換伺服器、連桿鎖、球頭
Drifting during flight 飛行飄移	pitching up or aileron drift during forward flight 直線飛行機頭上揚或副翼飄移	Swashplate gyro gain is slightly too low 十字盤陀螺儀感度偏低	Turn the gain dial on 3GX MRS clockwise, 10 degrees at a time until drifting is eliminated. 順時針調整3GX MRS上的感度調整旋鈕，以每次調整約10度的方式，調整至適當位置
Control Response 動作反應	Slow Forward/Aft/Left/Right input response 前後左右飛行動作反應偏慢	Roll rate too low 滾轉速率偏低	Adjust 3GX MRS roll rate dial clockwise. 順時針調整3GX MRS滾轉速率旋鈕
	Sensitive Forward/Aft/Left/Right input response 前後左右飛行動作反應偏快	Roll rate too high 滾轉速率偏快	Adjust 3GX MRS roll rate dial counter. 逆時針調整3GX MRS滾轉速率旋鈕

If above solution does not resolve your issues, please check with experienced pilots or contact your Align dealer.

※在做完以上調整後，仍然無法改善情況時，應立即停止飛行並向有經驗的飛手諮詢或連絡您的經銷商。

ALIGN

Specifications & Equipment/規格配備:

Length/機身長:431mm

Height/機身高:148mm

Main Blade Length/主旋翼長:205mm

Main Rotor Diameter/主旋翼直徑:460mm

Tail Rotor Diameter/尾旋翼直徑:100mm

Motor Pinion Gear/馬達主齒:15T

Main Drive Gear/傳動主齒:120T

Tail Drive Gear/尾翼傳動齒:28T

Drive Gear Ratio/齒輪傳動比:1:8:4.28

Weight (With Motor)/空機重:140g

Flying Weight(without battery)/全配重(不含電池):Approx. 250g

