



SAB HELI DIVISION AUSTRIA

GETS THE COMPETITION TREATMENT

Ihr Fireball Competition enthält alle hier abgebildeten Upgrades
Abweichende Artikelnummern sowie spezielle Aufbauhinweise finden Sie auf der Rückseite.



Verbesserte zyklische und kollektive Blattführung



Optimierte Heckanlenkung für mehr Stabilität

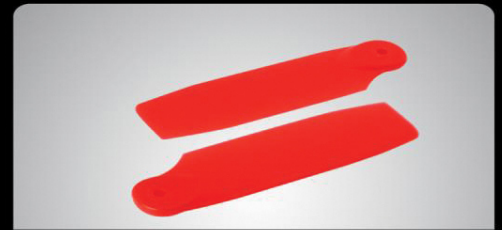

Bessere Erkennung der Fluglage



Besonders kräftiger Comp. Motor mit 60A Regler



Leichte GFK Kabinenhaube für bessere Performance



Carbon Heckausleger zur weiteren Reduzierung der Massen

Heckrotor Umlenkhebel

Bag 3.2

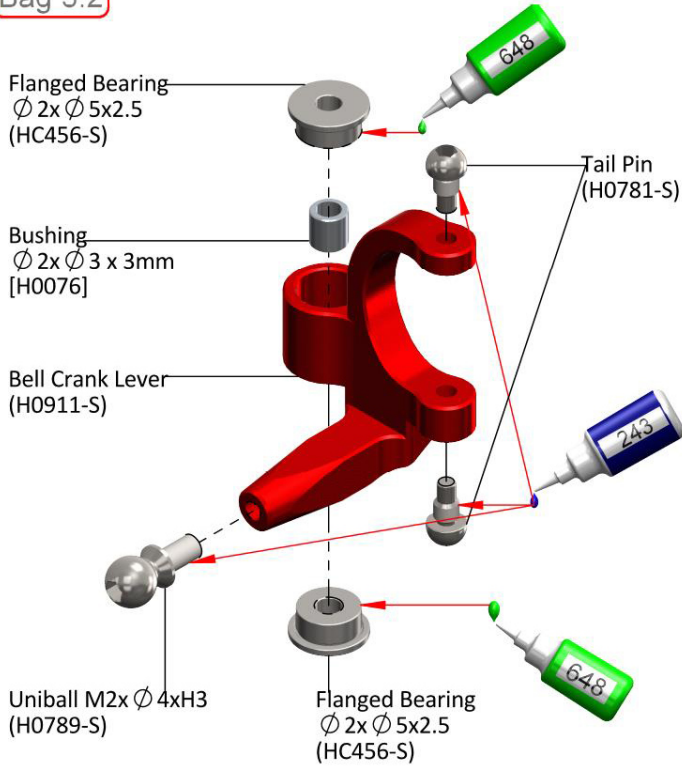

Pitch Arme Hauptrotor

Bag 7.1

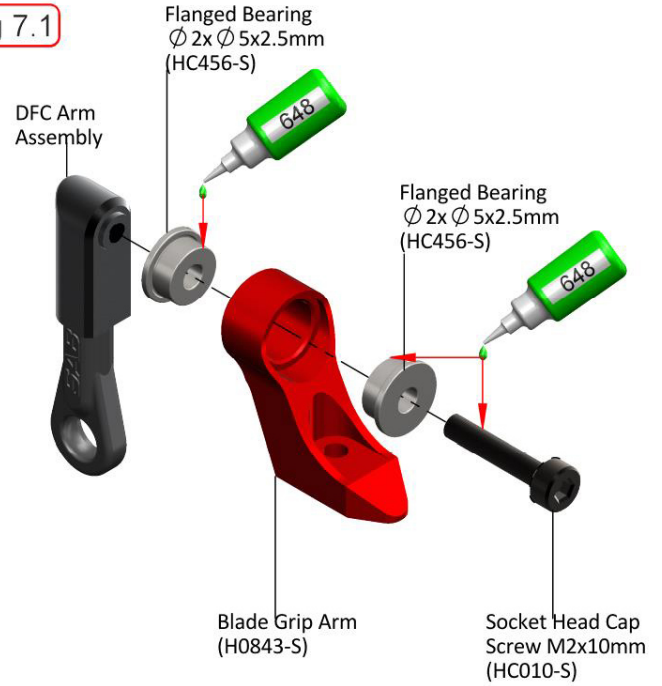

CFK Heckausleger / GFK Haube

