

# Introduction

The DJI FPV Air Unit is an advanced video transmission module that supports a 5.8 GHz digital video signal and 720p 60fps image transmission, with a transmission range of up to 4 km and a minimum end-to-end latency within 32 ms\*. The air unit can be mounted on a racing drone and used with DJI FPV Goggles or a remote controller to transmit video, control signals, and flight controller information wirelessly.

1. MMCX Antenna Ports
2. 3-in-1 Port
3. USB-C Port
4. microSD Card Slot
5. Link Button
6. Linking Status Indicator
7. Camera

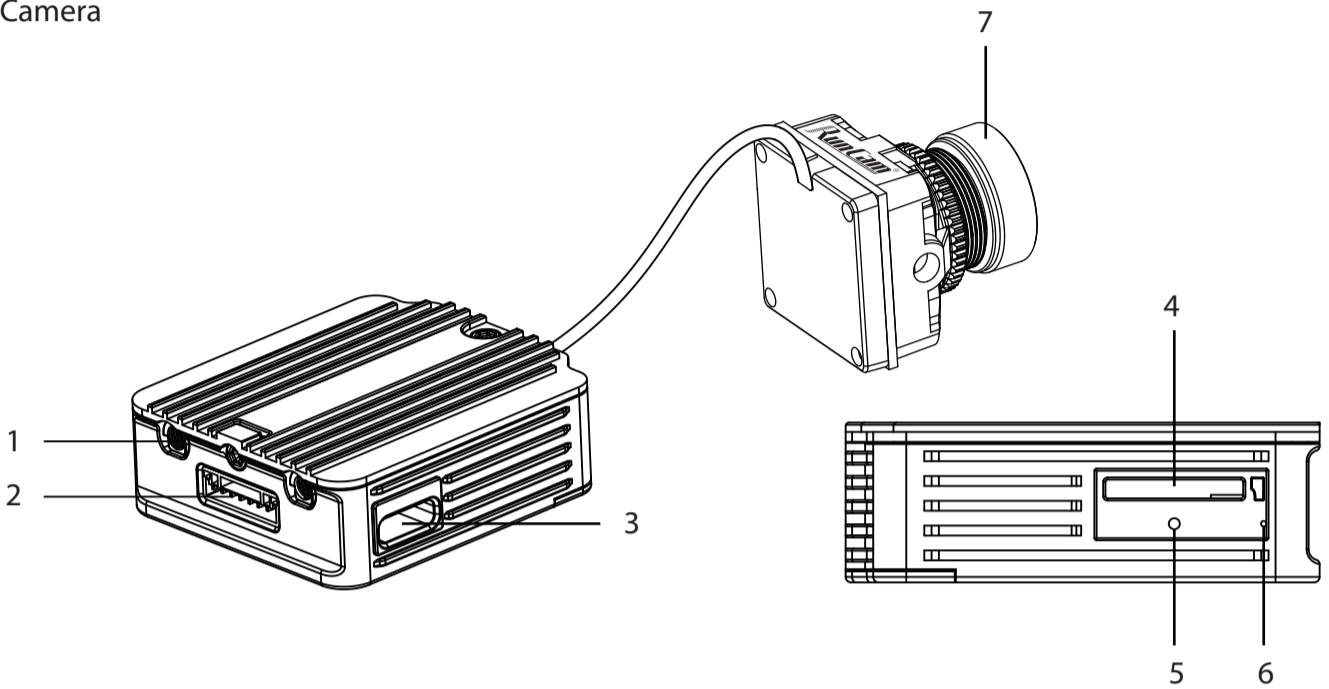

\*The end-to-end latency is the total time from camera input to screen display. The device is able to reach its minimum latency and maximum transmission distance (FCC) in a wide open area with no electromagnetic interference.

# Connection

Refer to the illustration below to mount and connect the air unit to a racing drone.

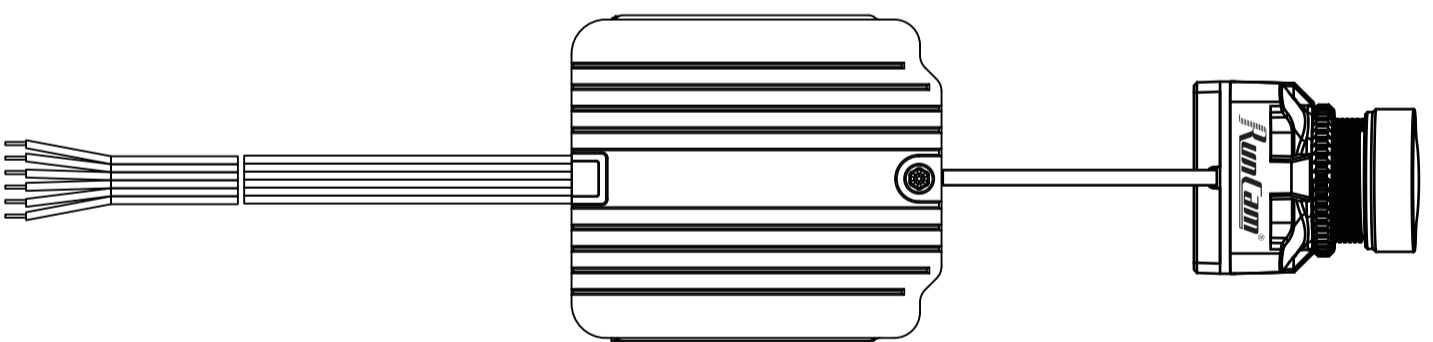

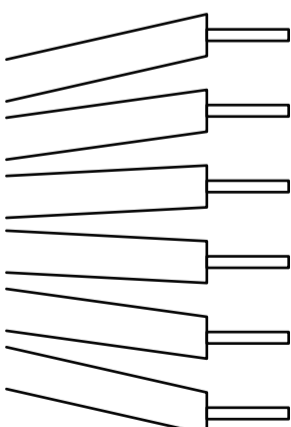
- 
- RED:** Power (7.4-17.6 V)
  - BLACK:** Power GND
  - WHITE:** UART-RX (Connects to Flight Controller OSD TX, 0-3.3 V)
  - GRAY:** UART-TX (Connects to Flight Controller OSD RX, 0-3.3 V)
  - BLACK:** Signal GND
  - YELLOW:** DJI HDL (Connects to Flight Controller S.Bus, 0-3.3 V)

## Technical Support

Please visit: <https://support.runcam.com>

## Warnings and tips

1. An electric soldering iron and soldering tin are required for connection. Make sure that there are no short circuits or open circuits when soldering the cables.
2. There are up to eight channels for the air unit depending on the region (FCC: eight, CE/SRRC: four, MIC: three). Each channel has a bandwidth of 20 MHz. The public channel is 8, which is the default channel when the equipment is powered on. The channel can be changed manually to avoid interference from other devices.
3. The air unit may become hot during or after operation. DO NOT touch the air unit before it cools down.
4. DO NOT use the air unit for an extended period when the temperature is high or there is poor ventilation. Otherwise, the air unit may overheat and enter low-power mode which will affect its performance. If the air unit enters low-power mode, restart it or wait for it to cool down and it will automatically return to normal.
5. Keep the antennas of the air unit at least 40 mm apart. Keep the air unit away from metal objects or carbon fiber frames. Make sure to choose a position where the transmission will not be blocked during flight.

## Activation

When powered on, connect the air unit to your computer and run DJI ASSISTANTTTM 2 for activation. Download DJI Assistant 2 at <https://www.dji.com/fpv/downloads>

## Linking

The air unit support three linking methods: A, B, and A+B (Must link A before B).

A

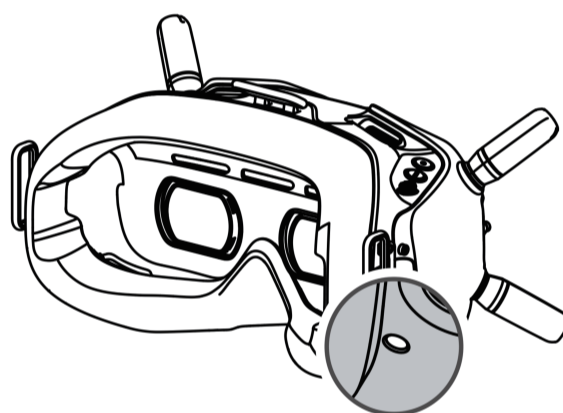
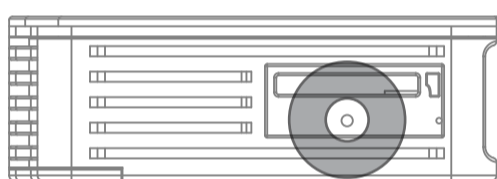

1. Power on the air unit and the DJI FPV Goggles.
2. Press the link button on the air unit and the goggles.\*
3. The linking status indicator of the air unit turns solid green. The goggles stop beeping when successfully linked and the video display is normal.

B

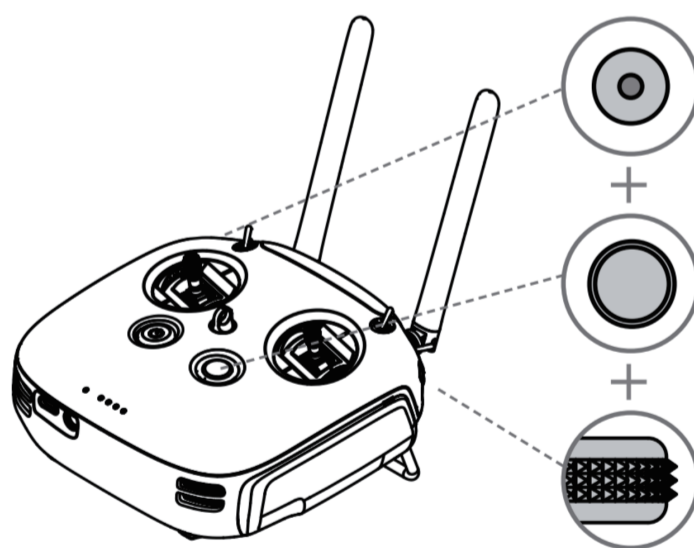

1. Power on the air unit and the DJI FPV Remote Controller.
2. Press the link button on the air unit, and then press the record button, C button, and right dial on the remote controller simultaneously.\*
3. Both the linking status indicators turn solid green when successfully linked.

\* When ready to link, the devices will give the following indication: Air unit: the linking status indicator turns solid red. Goggles: the goggles beep continually. Remote controller: the remote controller beeps continually and the status indicator blinks blue.

# Specifications

---

Weight	Air Unit (camera included): 40.5 g Antenna:3g (MMCX-90°)
Dimensions	Air Unit: 44×37.8×14.4 mm Camera: L19mm*W19mm*H23.5mm Coaxial Cable: 120 mm
Operating Frequency	5.725-5.850 GHz
Transmitter Power (EIRP)	FCC/SRRC: <30 dBm; CE: <14 dBm
Min. Latency (end-to-end)	720p 60fps: <32 ms
Max. Transmission Distance	FCC/SRRC: 4 km; CE: 0.7 km;
Video Format	MP4 (Video format: H.264;Audio format: AAC-LC)
I/O Interface	USB-C, MMCX, 3-in-1 port, microSD card slot
Supported Flight Control System	BetaFlight
Operating Temperature Range	0° to 40° C (32° to 104° F)
Power	7.4-17.6V
Camera	Sensor: 1/2" Resolution: 1280*720@60fps LENS: FOV D:157° H:133° V:72° Shutter: Rolling Shutter Net Weight: 7.5g

---